

Z1000 2011-20 • Z1000/SX 2011-19 • Ninja 1000SX 2020 • Versys 1000 2012-20

THIS SHEET INCLUDES FITTING INSTRUCTIONS FOR THE FOLLOWING PARTS:

Secondary Alternator Cover Part No. EC-Z1000SX-2016-1-GBR / Secondary Clutch Cover Part No. EC-Z1000SX-2016-2-GBR /

Secondary Pulse Cover Part No. EC-Z1000SX-2016-3-GBR

Paddock Stand Bobbin Set Part No. BA12-10-GBR-SET / Part No. BA12-8-GBR-SET



SECONDARY ALTERNATOR COVER PART NO. EC-Z1000SX-2016-1-GBR

1. Remove fairing (if fitted).
2. Remove 4 existing bolts from the stock Alternator cover, shown as position Bolt 1, 2, 3 & 4.
3. Place the Secondary Alternator Cover over the stock cover. Please Note: Do not remove fairing bracket as GBRacing Secondary Cover will fit over it.
4. Assemble 4 replacement bolts loosely in the correct positions as shown.
5. Tighten bolts to a Torque of 11Nm as per Manufacturer's recommendations. **DO NOT OVERTIGHTEN.**
6. Replace fairing.

NOTE: for Versys 1000:
Small modification required to the belly pan: Square off this section highlighted below in Fig 1.

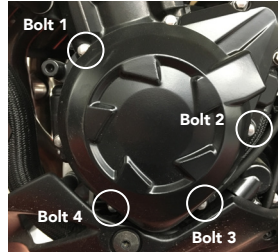

Bolt 1
M6X40HHF -
11Nm

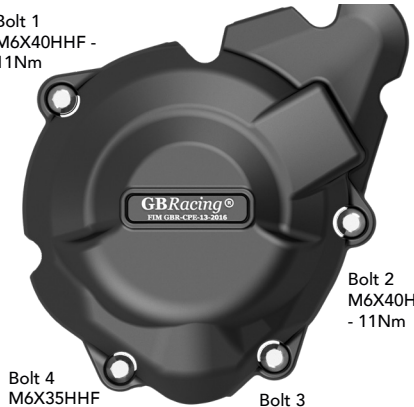

Bolt 2
M6X40HHF -
11Nm

Bolt 4
M6X35HHF -
11Nm

Bolt 3
M6X40HHF - 11Nm

SECONDARY CLUTCH COVER PART NO. EC-Z1000SX-2016-2-GBR

1. Remove fairing (if fitted).
2. Remove 4 existing bolts from the Clutch cover, shown as position Bolt 1, 2, 3 & 4.
3. Place the Secondary Clutch Cover over the stock cover.
4. Assemble 4 replacement bolts loosely in the correct position as shown.
5. Tighten bolts to a Torque of 11Nm as per Manufacturer's recommendations. **DO NOT OVERTIGHTEN.**
6. Replace fairing.

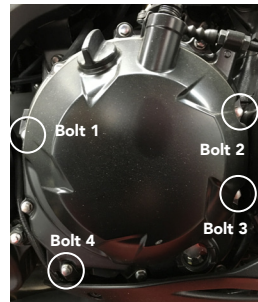

Bolt 1
M6X45HHF -
11Nm

Bolt 2
M6X35HHF -
11Nm

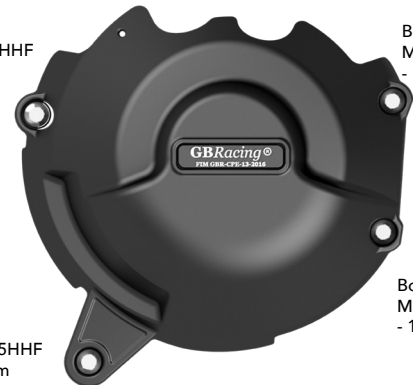

Bolt 3
M6X35HHF -
11Nm

Bolt 4
M6X35HHF -
11Nm

SECONDARY PULSE COVER PART NO. EC-Z1000SX-2016-3-GBR

1. Remove fairing (if fitted).
2. Remove 4 existing bolts from the Pulse cover, shown as position Bolt 1, 2, 3 & 4.
3. Place the Secondary Pulse Cover over the stock cover. Assemble 4 replacement bolts loosely in the correct position as shown.
4. Tighten bolts to a Torque of 11Nm as per Manufacturer's recommendations. **DO NOT OVERTIGHTEN.**
5. Replace fairing.

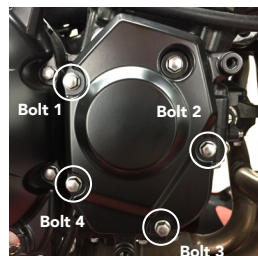

Bolt 1
M6X35 -
11Nm

Bolt 2
M6X35 -
11Nm

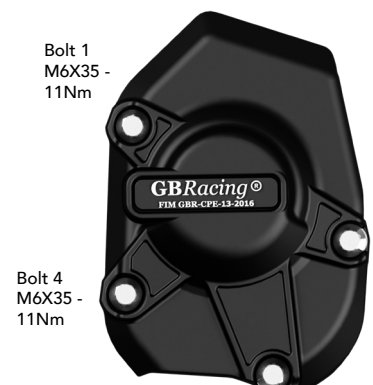

Bolt 4
M6X35 -
11Nm

Bolt 3
M6X35 - 11Nm

Z1000 2011-20 • Z1000/SX 2011-19 • Ninja 1000SX 2020

**PADDOCK STAND / BOBBIN SET
PART NO. BA12-10-GBR-SET**

- 1 Assemble the M10 Stainless Steel bolt through the moulded bobbin and the Black Anodised Bush.
- 2 Tighten bolts to the swing arm boss, 8 N/m.
DO NOT OVERTIGHTEN.

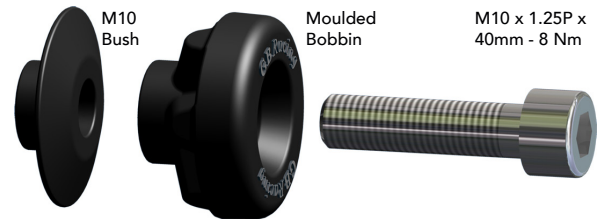
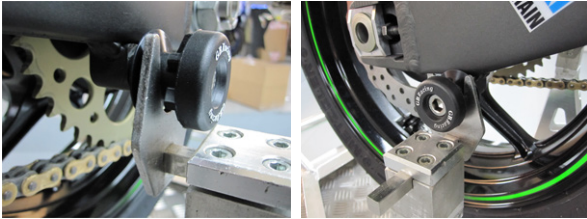

PADDOCK STAND / BOBBIN SET PART NO. BA12-8-GBR-SET

- 1 Assemble M8 x 40mm Bolt through the moulded bobbin.
- 2 Tighten bolts to swing arm boss, 8 Nm.
DO NOT OVERTIGHTEN

1 x M8 x 40 Bolt



1 x Moulded Paddock Stand / Bobbin