

THIS SHEET INCLUDES FITTING INSTRUCTIONS FOR THE FOLLOWING PARTS:

Secondary Alternator Cover Part No. EC-CBR650F-2014-1-GBR /

Secondary Clutch Cover Part No. EC-CBR650F-2014-2-GBR / Secondary Pulse Cover Part No. EC-CBR650F-2014-3-GBR



SECONDARY ALTERNATOR COVER
PART NO. EC-CBR650F-2014-1-GBR

- 1 Remove nearside lower belly panel.
- 2 4 existing bolts from the stock Alternator cover, shown as position Bolt 1, 2, 3 & 4.
- 3 Place the Secondary Alternator Cover over the stock cover.
- 4 Assemble 4 replacement bolts loosely in the correct positions as shown.
- 5 Tighten bolts to a Torque of 10Nm as per Manufacturer's recommendations. **DO NOT OVERTIGHTEN.**
- 6 Replace nearside lower belly panel.

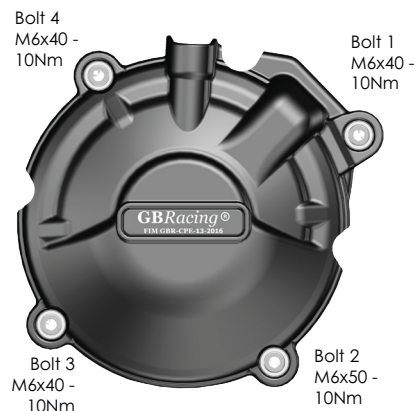
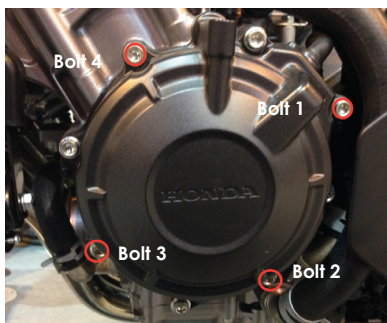

SECONDARY CLUTCH COVER
PART NO. EC-CBR650F-2014-2-GBR

- 1 4 existing bolts from the stock Clutch cover, shown as position Bolt 1, 2, 3 & 4.
- 2 Place the Secondary Clutch Cover over the stock cover.
- 3 Assemble 4 replacement bolts loosely in the correct positions as shown.
- 4 Tighten bolts to a Torque of 10Nm as per Manufacturer's recommendations. **DO NOT OVERTIGHTEN.**

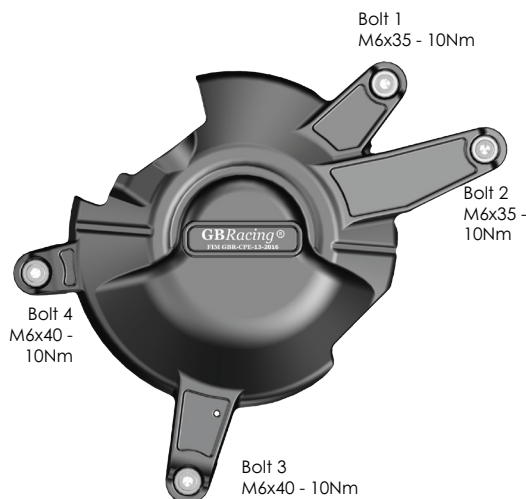
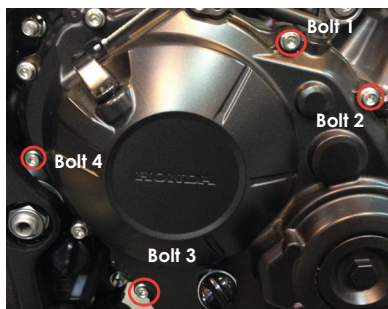

SECONDARY PULSE COVER
PART NO. EC-CBR650F-2014-3-GBR

- 1 Remove 4 existing bolts from the stock pulse cover, shown as position Bolt 1, 2, 3 & 4.
- 2 Place the Secondary Pulse Cover over the stock cover.
- 3 Assemble 4 replacement bolts loosely in the correct positions as shown. If you have an unfaired CB650F, please use the spacer washers supplied at Bolt Position 2 & 3. Place this spacer in between the GBR engine cover and the original Honda cover in these 2 positions.
- 4 Tighten bolts to a Torque of 10Nm as per Manufacturer's recommendations. **DO NOT OVERTIGHTEN.**

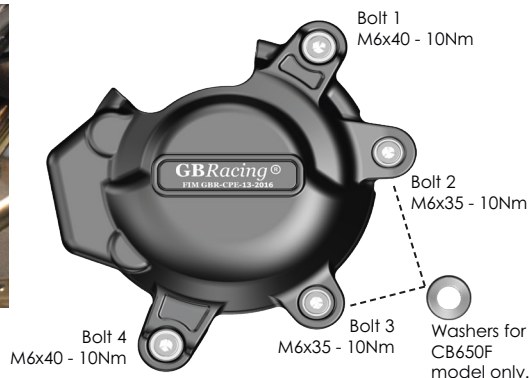
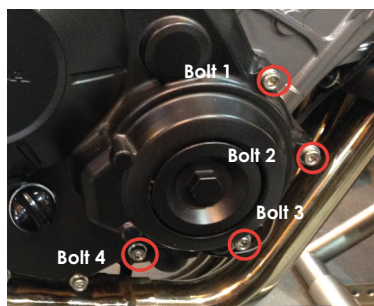

Engine Cover Set: EC-CBR650F-2014-SET-GBR

EC-CBR650F-2014-1-GBR, EC-CBR650F-2014-2-GBR, EC-CBR650F-2014-3-GBR

www.GBRacing.eu