

### STOCK 6mm

THIS SHEET INCLUDES FITTING INSTRUCTIONS FOR THE FOLLOWING PARTS:

Secondary STOCK Alternator Cover Part No. EC-D675-1-GBR / Secondary Clutch Cover Part No. EC-D675-2-GBR /

Secondary Pulse Cover Part No. EC-D675-3-GBR

Bullet Frame Race Slider Set - STREET - Part No. FS-675-2006-CS-S / Bobbin Set Part No. BA12-6-GBR-SET /

Lower Chain Guard Part No. CGA06-GBR / Front Spindle Protectors Part No. BA-675-SET-GBR



#### SECONDARY ALTERNATOR COVER - **STOCK** - PART NO. EC-D675-1-GBR

- 1 Remove 4 off existing Bolts on the stock aluminium Alternator cover that correspond to the Secondary Alternator Cover.
- 2 Place the Secondary Alternator Cover over the stock aluminium alternator cover.
- 3 Loosely assemble M6x30 Bolts 1, 2, 3 & 4 in an anti clockwise direction, starting at Bolt Position 1.
- 4 Tighten all 4 bolts to a torque of 8 N/m as per manufacturer's recommendations.

DO NOT OVERTIGHTEN

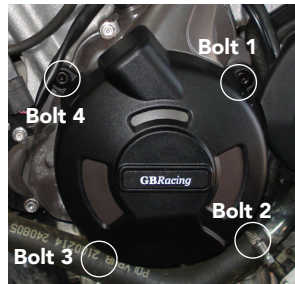

#### SECONDARY CLUTCH COVER PART NO. EC-D675-2-GBR

- 1 Remove 4 off existing Bolts on the stock aluminium Clutch cover that correspond to the Secondary Clutch Cover.
- 2 Place the Secondary Clutch Cover over the stock aluminium clutch cover.
- 3 Loosely assemble M6x30 Bolts 1, 2, 3 & 4 in an anti clockwise direction, starting at Bolt Position 1.
- 4 Tighten all 4 bolts to a torque of 8 N/m as per manufacturer's recommendations.

DO NOT OVERTIGHTEN

*Note: You may need to bend the moulded arm at Bolt 4 to line up correctly*

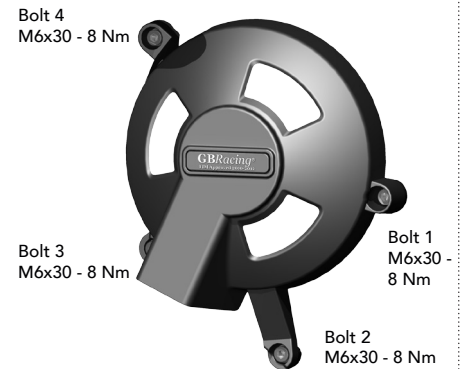
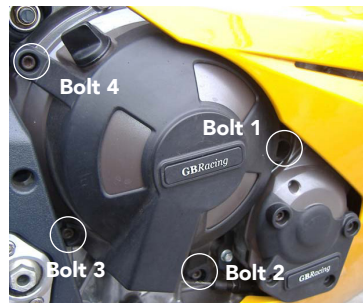

#### SECONDARY PULSE COVER PART NO. EC-D675-3-GBR

- 1 Remove 4 off existing Bolts at the base of the stock aluminium Pulse cover.
- 2 Place the Secondary Pulse Cover over the stock aluminium Pulse cover.
- 3 Loosely assemble the top 2 M6x30 Bolts 1&2 then assemble the bottom 2 M6x25 Bolts 3&4.
- 4 Tighten all 4 bolts to a torque of 8 N/m as per manufacturer's recommendations.

DO NOT OVERTIGHTEN

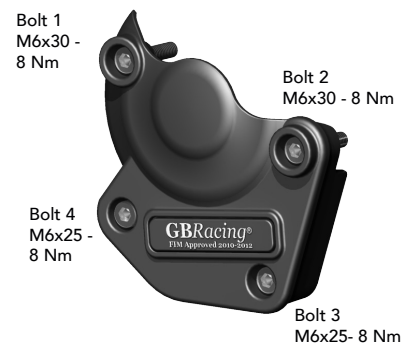
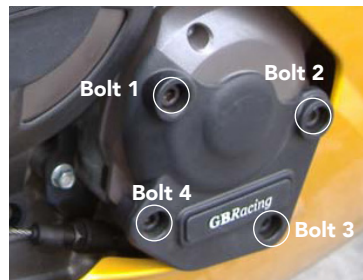

#### LOWER CHAIN GUARD PART NO. CGA06-GBR

- 1 Assemble 2 off M6 washers on to 2 off M6 x 20mm Bolts
  - 2 Line up the Moulded Chain Guard to the Swing Arm bosses.
  - 3 Assemble the M6 bolts through the 2 fixing holes on the aligned chain guard.
  - 4 Assemble remaining 2 off M6 washers & M6 Lock Nuts onto the M6 bolts
- DO NOT OVERTIGHTEN.



**STOCK 6mm**

### BULLET FRAME SLIDER - LEFT HAND SIDE - STREET

#### PART NO. FS-675-2006-LHS-SET-S

1. Remove left side fairing
  2. Unscrew engine bolts 1 & 2 as shown. Retain M10 locking nuts from Bolt 1.
  3. Assemble black anodised bracket. Use 1 off M10 x 120 x 1.25 & 1 off M10 x 60 x 1.25 nickel plated bolts. Re-use the original M10 locking nut.
- Note: You may need to loosen the Air Breather Bottle temporarily.
4. Tighten both bolts to 48 N/m, as per manufacturers recommendations.
  5. Re-assemble Left side fairing
  6. Assemble Crash Mushroom FS-675-2006-LHS-S. Tighten to 25 N/m DO NOT OVERTIGHTEN

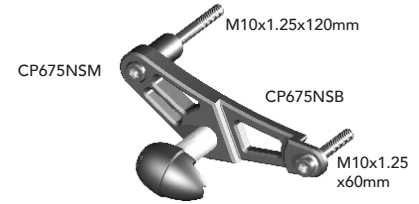
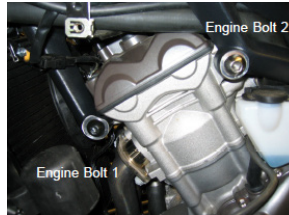

### BULLET FRAME SLIDER - RIGHT HAND SIDE - STREET

#### PART NO. FS-675-2006-RHS-SET-S

1. Remove right side fairing
  2. Unscrew engine bolts 1 & 2 as shown. Retain M10 locking nuts from Bolt 1.
  3. Assemble black anodised bracket. Use 1 off M10 x 120 x 1.25 & 1 off M10 x 60 x 1.25 nickel plated bolts. Re-use the original M10 locking nut.
- Note: You may need to loosen the Air Breather Bottle temporarily.
4. Tighten both bolts to 48 N/m, as per manufacturers recommendations.
  5. Re-assemble Right side fairing
  6. Assemble Crash Mushroom FS-675-2006-LHS-S. Tighten to 25 N/m. DO NOT OVERTIGHTEN

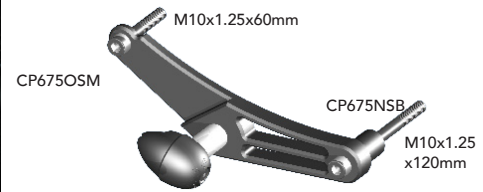
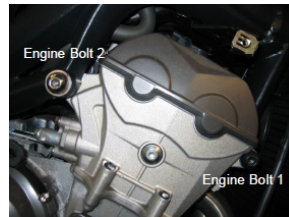

### FRONT SPINDLE PROTECTORS - LEFT HAND SIDE

#### PART NO. BA-675-LHS-GBR

1. Assemble the Stainless Steel bar through the front spindle.
  2. Place the Left Hand Side spindle protector assembly over the bar.
  3. Assemble the M6 Washer first, then the lock nut. (The Washer must be used).
- Note: You can prevent the bar from rotating by holding the opposite end of the bar by the slot providing with a flat headed screw driver.
4. When both ends are fitted, tighten the lock nuts together to a Torque of 10Nm. There should be approximately 2-3 threads equally showing over the lock nuts. DO NOT OVERTIGHTEN.

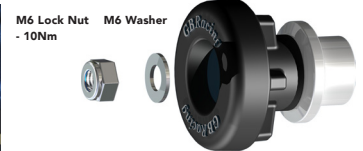

### FRONT SPINDLE PROTECTORS - RIGHT HAND SIDE

#### PART NO. BA-675-RHS-GBR

1. Assemble the Stainless Steel bar through the front spindle.
  2. Place the Right Hand Side spindle protector assembly over the bar.
  3. Assemble the M6 Washer first, then the lock nut. (The Washer must be used).
- Note: You can prevent the bar from rotating by holding the opposite end of the bar by the slot providing with a flat headed screw driver.
4. When both ends are fitted, tighten the lock nuts together to a Torque of 10Nm. There should be approximately 2-3 threads equally showing over the lock nuts. DO NOT OVERTIGHTEN.

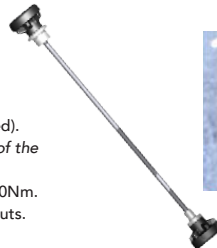

Note: With all 2007-2009 Triumph 675 models, the correct version to use is our 6mm version. With all 2010 models, Triumph produced two different swing arm types during that year, one with 6mm bobbins and the other with 8mm bobbins. Therefore, if you have a 2010 model, you will need to check using a 6 or 8mm bolts, which are the correct ones for your motorcycle.

### PADDOCK STAND / BOBBIN SET

#### PART NO. BA12-6-GBR-SET

1. Assemble M6 x 40mm Bolt & M6 Washer through the moulded bobbin.
2. Tighten bolts to swing arm boss, 8 Nm. DO NOT OVERTIGHTEN

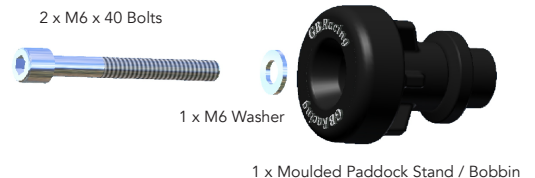

### Protection Bundle: CP675-CS-GBR

EC-D675-1-GBR, EC-D675-2-GBR, EC-D675-3-GBR, CGA06-GBR, BA12-6-GBR-SET, BA-675-GBR-SET, FS-675-2006-CS-S

### Engine Cover Set: EC-D675-SET-GBR

EC-D675-1-GBR, EC-D675-2-GBR, EC-D675-3-GBR