



**THIS SHEET INCLUDES FITTING INSTRUCTIONS FOR THE FOLLOWING PARTS:**

Secondary Alternator Cover Part No. EC-S1000RR-2019-1-GBR / Secondary Clutch Cover Part No. EC-S1000RR-2019-2-GBR /  
Secondary Pulse Cover Part No. EC-S1000RR-2019-3-GBR / Secondary Water Pump Cover Part No. EC-S1000RR-2019-5-GBR /  
Bullet Frame Sliders FS-S1000RR-2019-R



**SECONDARY ALTERNATOR COVER – PART NO. EC-S1000RR-2019-1-GBR**

- 1 Remove 4 existing stretch bolts from the stock Alternator cover, shown as position Bolt 1, 2, 3 & 4.
- 2 Place the Secondary Alternator Cover over the stock cover.
- 3 Assemble 4 replacement stainless steel M6X40A2 TORX bolts loosely in the correct position as shown.
- 4 Tighten bolts to a Torque of 10Nm. DO NOT OVERTIGHTEN.

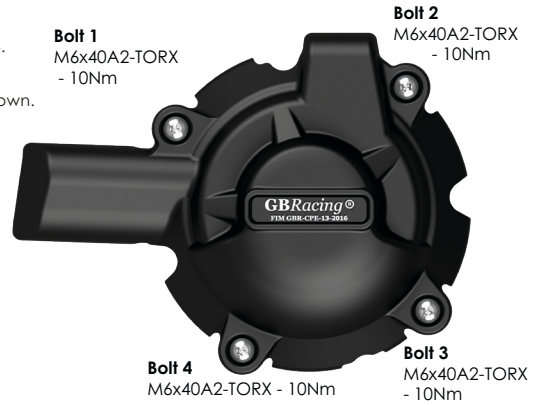
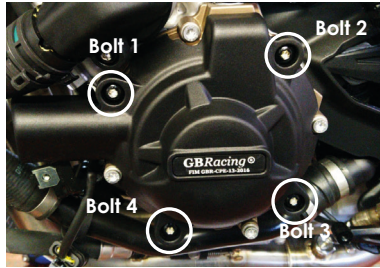
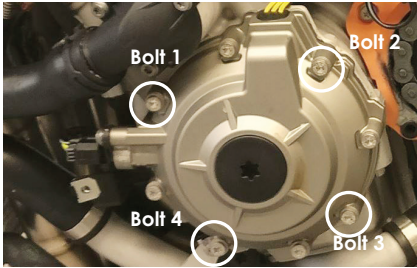

**SECONDARY CLUTCH COVER – PART NO. EC-S1000RR-2019-2-GBR**

- 1 Remove Upper fairing.
- 2 Remove 4 existing bolts from the stock clutch cover, shown as position Bolt 1, 2, 3 & 4.
- 3 Place the Secondary Clutch Cover over the stock cover.
- 4 Assemble 4 replacement M6X40A2 TORX bolts, loosely in the correct position as shown.
- 5 Tighten bolts to a Torque of 10Nm. DO NOT OVERTIGHTEN.
- 6 Re-Fit Upper Fairing.

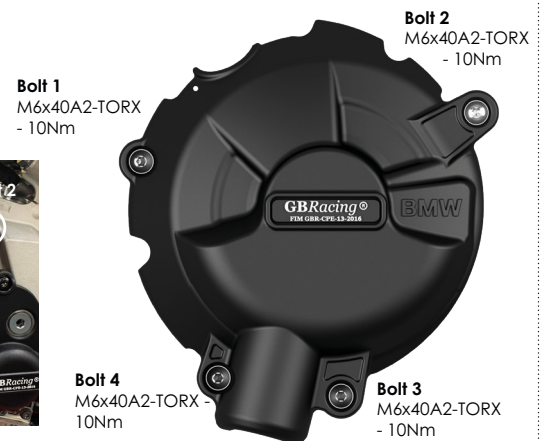
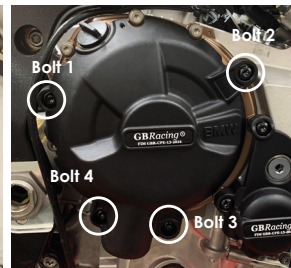
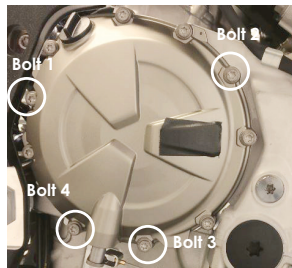

**SECONDARY PULSE COVER – PART NO. EC-S1000RR-2019-3-GBR**

- 1 Remove 3 existing bolts indicated in **Fig 1**.
- 2 Fit GBRacing fixing bracket to existing bracket as shown in **Fig 2**.
- 3 Fixing bracket is fitted to engine using existing clutch cable mount.
- 4 Place the Secondary Pulse Cover over these bolt positions in **Fig 1**.
- 5 Assemble 2 replacement M6X40A2 TORX bolts, loosely in the correct position as shown at bolt positions 1 & 3.
- 6 Bolt 2 M6X30A2 TORX will secure to the fixing bracket as indicated in **Fig 2 & 3**.
- 7 Tighten bolts to a Torque of 10Nm. DO NOT OVERTIGHTEN.

**Fig 1.**

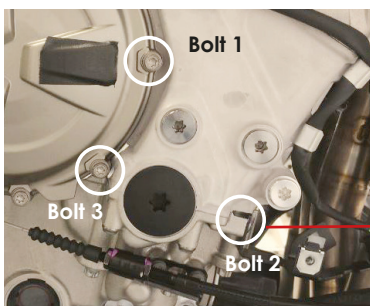

**Fig 2.**  
Fixing Bracket (EC-S1000RR-2019-3-FB-GBR)  
for Bolt 2

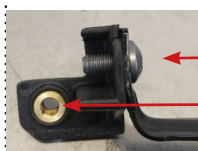

Use OE mounting bolt here  
Bolt 2 M6X30A2 mounting point

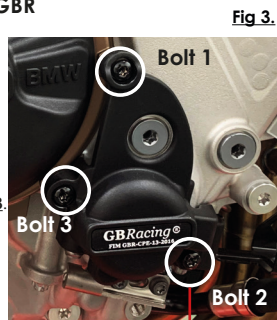

**Fig 3.**

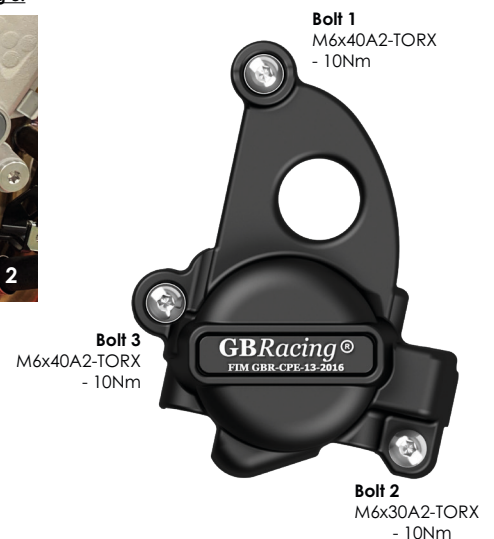

**ENGINE COVER SET: EC-S1000RR-2019-SET-GBR:**

EC-S1000RR-2019-1-GBR, EC-S1000RR-2019-2-GBR, EC-S1000RR-2019-3-GBR, EC-S1000RR-2019-3-FB-GBR, EC-S1000RR-2019-5-GBR



**S1000RR 2019-2020**

# FITTING INSTRUCTIONS

TO BE FITTED BY A QUALIFIED TECHNICIAN



## SECONDARY WATER PUMP COVER PART NO. EC-S1000RR-2019-5-GBR

- 1 Fitting requires a COLD engine.
- 2 Decompress the system before loosening existing stock bolts.
- 3 Have all 3 Replacement Bolts to hand before removing existing stock bolts.
- 4 Loosen bottom fairing bolt to enable access to the Water Pump.
- 5 Remove 3 existing bolts from the stock water pump cover shown as bolt positions 1, 2 & 3
- 6 Place the Secondary Water Pump Cover over the stock cover.
- 7 Assemble 3 replacement bolts, loosely in the correct position as shown.
- 8 Tighten bolts to a Torque of 10Nm. **DO NOT OVERTIGHTEN.**
- 9 Tighten bottom fairing bolt.
- 10 Check coolant level & top up if necessary before starting engine.

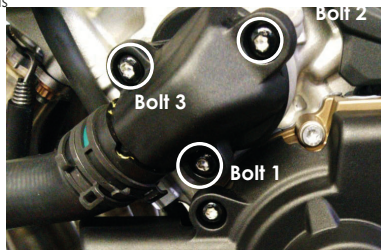

**Bolt 1**  
M6X30A2-TORX  
- 10Nm

**Bolt 2**  
M6X30A2-TORX  
- 10Nm



**Bolt 3**  
M6X30A2-TORX  
- 10Nm

## BULLET FRAME SLIDER SET: PART NO. FS-S1000RR-2019-R:

### BULLET FRAME SLIDER - LEFT HAND SIDE - RACE PART NO. FS-S1000RR-2019-LHS-R

- 1 Remove fairing.
- 2 Remove upper engine mounting bolt.
- 3 Assemble bolt through the aluminium bush into correct position.
- 4 Drill fairing.
- 5 Tighten to 40Nm torque.
- 6 Replace fairing.
- 7 Slide bullet moulding onto aluminium bush.
- 8 Screw M6 bolt into front of bullet moulding hand tight.



CPM-3

CPB-10-20

M10x55



### BULLET FRAME SLIDER - RIGHT HAND SIDE - RACE PART NO. FS-S1000RR-2019-RHS-R

- 1 Remove fairing.
- 2 Remove upper engine mounting bolt.
- 3 Assemble bolt through the aluminium bush into correct position.
- 4 Drill fairing.
- 5 Tighten to 40Nm torque.
- 6 Replace fairing.
- 7 Slide bullet moulding onto aluminium bush.
- 8 Screw M6 bolt into front of bullet moulding hand tight.



CPM-3

CPB-10-15

M10x55



## FRAME PROTECTOR SET: PART NO. FP-S1000RR-2019-SET-GBR:

### LEFT HAND SIDE FRAME PROTECTOR PART NO. FP-S1000RR-2019-LHS-GBR

- 1 Remove fairing.
- 2 Hold left hand frame protector in correct position and mark chassis.
- 3 Drill and tap chassis in correct locations.
- 4 Mount frame protector.
- 5 Replace fairing.



### RIGHT HAND SIDE FRAME PROTECTOR PART NO. FP-S1000RR-2019-RHS-GBR

- 1 Remove fairing.
- 2 Drill and tap chassis in correct locations IF REQUIRED.
- 3 Fix frame protector to chassis.
- 3 Replace fairing.



[www.GBRacing.eu](http://www.GBRacing.eu)

DO NOT use these products unless you agree to our Terms & Conditions, as shown on our paperwork and website. If you do not agree, please return the product(s) to your dealer for a refund.