

THIS SHEET INCLUDES FITTING INSTRUCTIONS FOR THE FOLLOWING PARTS:

Secondary Alternator Cover Part No. EC-CBR600RR-2024-1-GBR / Secondary Clutch Cover Part No. EC-CBR600RR-2024-2-GBR

Secondary Pulse/Timing Cover Part No. EC-CBR600RR-2024-3-GBR

Bullet Frame Sliders - Part No. FS-CBR600-2008-R/L & Bullet Frame Sliders SET - Part No. FS-CBR600-2008-R

SECONDARY ALTERNATOR COVER

PART NO. EC-CBR600RR-2024-1-GBR | EC-CBR600RR-2024-1-K-GBR

- 1 Remove 4 existing bolts from the stock Alternator cover, shown as position Bolt 1,2,3 & 4.
- 2 Place the Secondary Alternator Cover over the stock cover.
- 3 Assemble 4 replacement bolts loosely in the correct position as shown.
- 4 Tighten bolts to a Torque of 10Nm as per Manufacturer's recommendations.
DO NOT OVERTIGHTEN.

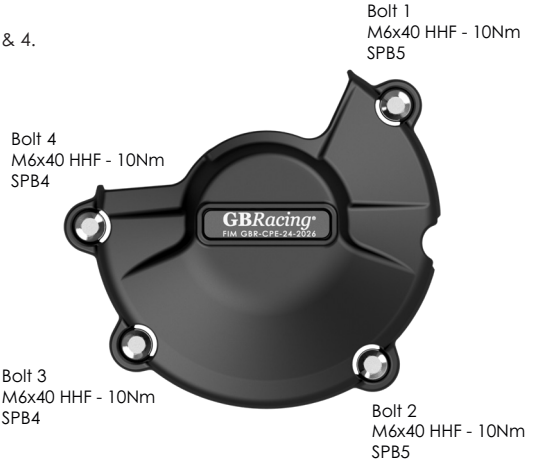
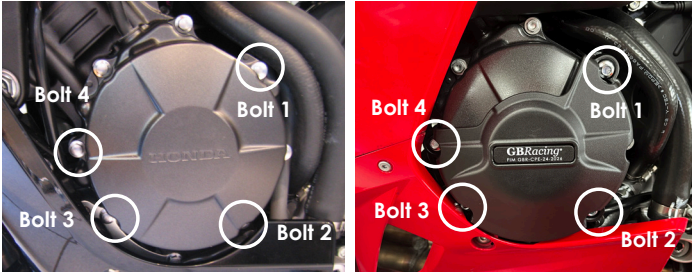

SECONDARY CLUTCH COVER

PART NO. EC-CBR600RR-2024-2-GBR

- 1 Remove 3 existing bolts from the stock Clutch cover, shown as position Bolt 1, 2 & 3.
- 2 Place the Secondary Clutch Cover over the stock cover.
- 3 Assemble 3 replacement bolts loosely in the correct position as shown.
- 4 Tighten bolts to a Torque of 10Nm as per Manufacturer's recommendations.
DO NOT OVERTIGHTEN.

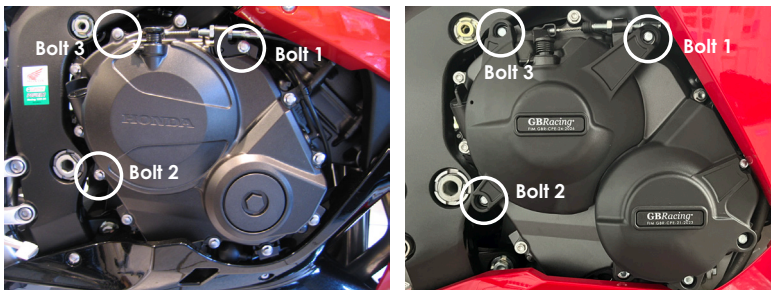

SECONDARY PULSE/TIMING COVER

PART NO. EC-CBR600RR-2024-3-GBR

- 1 Remove fairing.
- 2 Remove 4 existing bolts from the stock Pulse cover, shown as position Bolt 1, 2, 3 & 4.
- 3 Place the Secondary Clutch Cover over the stock cover.
- 4 Assemble 4 replacement bolts loosely in the correct position as shown.
- 5 Tighten bolts to a Torque of 10Nm as per Manufacturer's recommendations.
DO NOT OVERTIGHTEN.
- 6 Re-fit fairing.

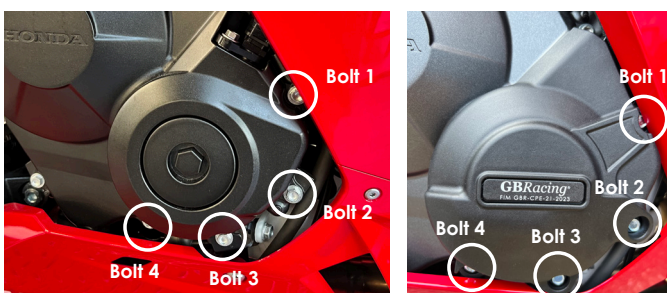

BULLET FRAME SLIDER - LEFT/RIGHT HAND SIDE - RACE
PART NO. FS-CBR600-2008-R/L



INSTRUCTIONS FOR THESE PARTS:

- 1 Remove fairing.
- 2 Remove upper engine mounting bolt, located through the fairing opening.
- 3 Assemble bolt through the aluminium bush and extension bush into correct position.
- 4 Drill fairing.
- 5 Tighten to 44Nm torque.
- 6 Replace fairing.
- 7 Slide bullet moulding onto aluminium bush.
- 8 Screw M6 bolt into front of bullet moulding hand tight.

BULLET FRAME SLIDER SET - PART NO. FS-CBR600-2008-R (Comprises of 2x FS-CBR600-2008-R/L)