

THIS SHEET INCLUDES FITTING INSTRUCTIONS FOR THE FOLLOWING PARTS:

Secondary Alternator Cover Part No. EC-R3-2015-1-GBR / Secondary Clutch Cover Part No. EC-R3-2015-2-GBR /
Secondary Water Pump Cover Part No. EC-R3-2015-5-GBR /
Paddock Stand Bobbin Set Part No. BA12-6-GBR-SET / Lower Chain Guard Part No. CGA09-GB
Bullet Frame Slider SET Part No: FS-R3-2015-R



SECONDARY ALTERNATOR COVER
PART NO. EC-R3-2015-1-GBR

- 1 Remove Fairing.
- 2 Remove 4 existing bolts from the stock Alternator cover, shown as position Bolts 1, 2, 3 & 4.
- 3 Place the Secondary Alternator Cover over the stock cover.
- 4 Assemble 4 replacement bolts loosely in the correct position as shown.
- 5 Tighten bolts to a Torque of 10Nm as per Manufacturer's recommendations. **DO NOT OVERTIGHTEN.**
- 6 Replace Fairing.

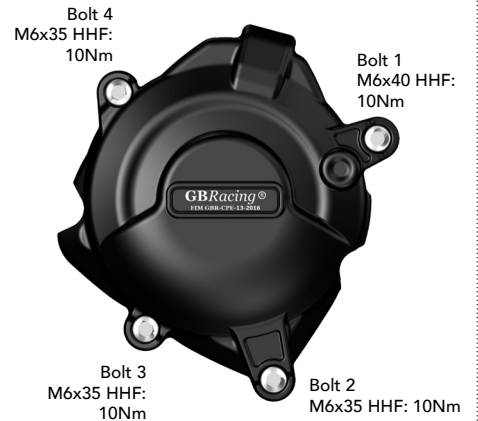

SECONDARY CLUTCH COVER
PART NO. EC-R3-2015-2-GBR

PLEASE NOTE: This part **DOES NOT FIT** the 2019-20 models because it touches the fairing. It **WILL FIT** with race fairing.

- 1 Loosen off clutch cable. No need to remove.
- 2 Remove 4 existing bolts from the stock Clutch cover, shown as position Bolt 1, 2, 3 & 4.
- 3 Place the Secondary Clutch Cover over the stock cover.
- 4 Assemble 4 replacement bolts loosely in the correct positions as shown.
- 5 Tighten bolts to a Torque of 10Nm as per Manufacturer's recommendations. **DO NOT OVERTIGHTEN.**
- 6 Re-tighten clutch cable.

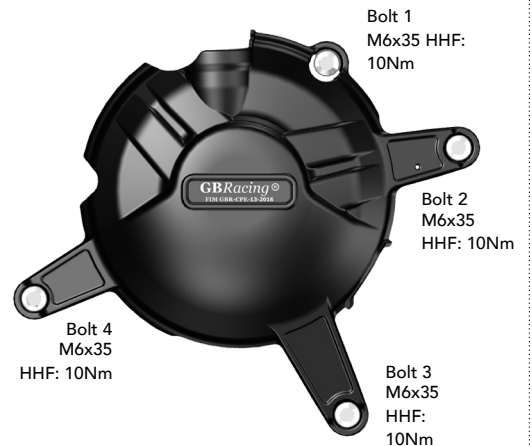
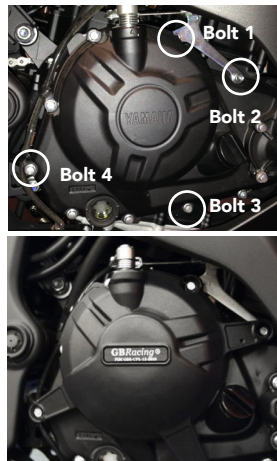

SECONDARY WATER PUMP COVER
PART NO. EC-R3-2015-5-GBR

- 1 Remove fairing.
- 2 Remove 3 existing bolts from the stock water pump cover, shown as position Bolt 1, 2, 3, retaining copper washer at Bolt 3.
- 3 Place the Secondary Water Pump Cover over the stock cover.
- 4 Assemble 3 replacement bolts loosely in the correct positions as shown, placing the two supplied Copper Washers on Bolt 3 as shown in **Fig. 1**. Please note: do not re-use old washer, only use the two new supplied copper washers.
- 5 Tighten bolts to 10Nm as per Manufacturer's recommendations. **DO NOT OVERTIGHTEN.**
- 6 Replace fairing.

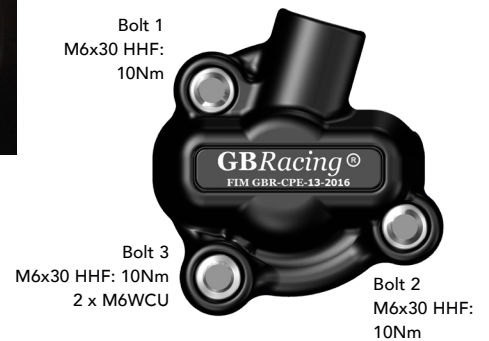
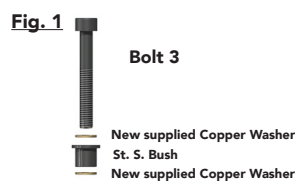
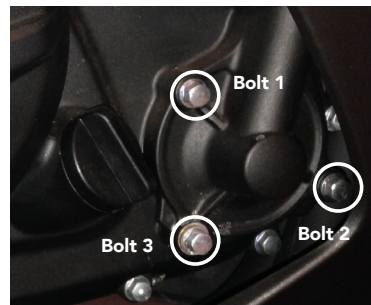

RACE Bullet Frame Slider SET Part No: FS-R3-2015-R:



BULLET FRAME SLIDER - LEFT HAND SIDE - RACE
PART NO. FS-R3-2015-LHS-R

- 1 Remove fairing.
- 2 Remove front engine mounting bolt.
- 3 Assemble bolt through the aluminium bush into correct position.
- 4 Mark and drill fairing.
- 5 Tighten to 40Nm torque.
- 6 Replace fairing.
- 7 Slide bullet moulding onto aluminium bush.
- 8 Screw M6 bolt into front of bullet moulding hand tight.



BULLET FRAME SLIDER - RIGHT HAND SIDE - RACE
PART NO. FS-R3-2015-RHS-R

- 1 Remove fairing.
- 2 Remove front engine mounting bolt.
- 3 Assemble bolt through the aluminium bush into correct position.
- 4 Mark and drill fairing.
- 5 Tighten to 40Nm torque.
- 6 Replace fairing.
- 7 Slide bullet moulding onto aluminium bush.
- 8 Screw M6 bolt into front of bullet moulding hand tight.



PADDOCK STAND / BOBBIN SET
PART NO. BA12-6-GBR-SET

- 1 Assemble M6 x 40mm Bolt & M6 Washer through the moulded bobbin.
- 2 Tighten bolts to swing arm boss, 8 Nm.
DO NOT OVERTIGHTEN

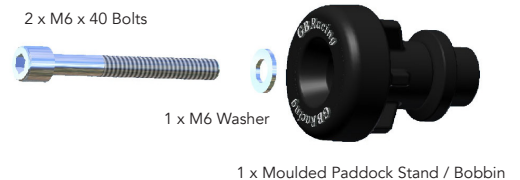

LOWER CHAIN GUARD
PART NO. CGA09-GBR

- 1 Assemble 2 off M6 x 20mm bolts and washers through the moulded lower chain guard into the Black Anodised aluminium mounting block CGA09-2.
- 2 Position the assembly underneath the swing arm, closing the gap to the rear sprocket.
Note : There should be a 5mm minimum gap from the bike chain to the lower chain guard.
- 3 Mark the position of the Black Anodised block, relative to the swing arm.
- 4 Disassemble the assembly, leaving the block to be replaced into the correct position.
Mark the C/Sunk fixing hole positions on the underside of the swing arm.
- 5 Drill & Tap the marked holes , M6 - (Drill 5mm Dia. for tapping)
- 6 Re-assemble the lower chain guard to the fixed block.

