

THIS SHEET INCLUDES FITTING INSTRUCTIONS FOR THE FOLLOWING PARTS:

Secondary Alternator Cover Part No. EC-R1-2007-1-GBR / Secondary Clutch Cover Part No. EC-FZ8-2010-2-GBR /
 Secondary Pulse Cover Part No. EC-FZ8-2010-3-GBR / Secondary Crank Cover Part No. EC-FZ8-2010-4-GBR /
 Paddock Stand / Bobbin Set Part No. BA12-6-GBR-SET / Lower Chain Guard Part No. CGA10-GBR



SECONDARY ALTERNATOR COVER
PART NO. EC-R1-2007-1-GBR

- 1 Remove the Belly Pan (Not Applicable for FZ8/FZ1).
- 2 Remove 3 off existing bolts on the stock aluminium Alternator cover, corresponding to the STOCK Secondary Engine Alternator Cover. Shown as bolt positions 1, 2 & 3.
 Note: Retain the steel bracket found at Bolt Position 1, in place. (If bracket is not present use M6 washers to space accordingly).
- 3 Place the Secondary Engine Alternator cover over the stock aluminium alternator cover. Loosely screw down Bolt 1, lining up the Steel Bracket, then the remaining Bolts as supplied, M6x35mm Cap Head Bolts.
- 4 Tighten all 3 bolts to a torque of 10 N/m as per Manufacturer's recommendations. **DO NOT OVERTIGHTEN**
- 5 Refit the Belly Pan.

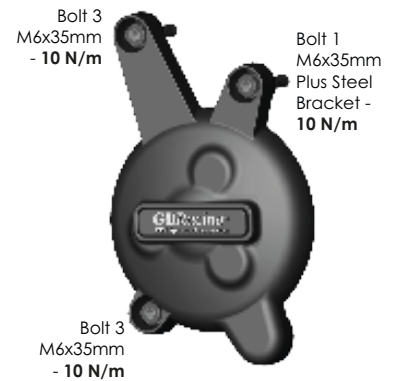

SECONDARY CLUTCH COVER
PART NO. EC-FZ8-2010-2-GBR

- 1 Remove 4 existing bolts from the stock pulse cover, shown as position Bolt 1, 2, 3 & 4.
- 2 Place the Secondary Clutch Cover over the stock cover.
- 3 Assemble 4 replacement M6x45, loosely in the correct position as shown.
- 4 Tighten bolts to a Torque of 10Nm as per Manufacturer's recommendations.
DO NOT OVERTIGHTEN.

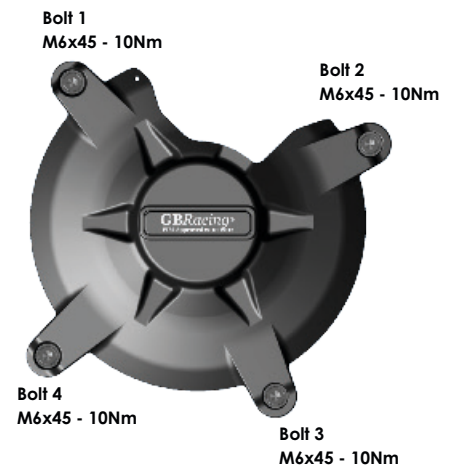
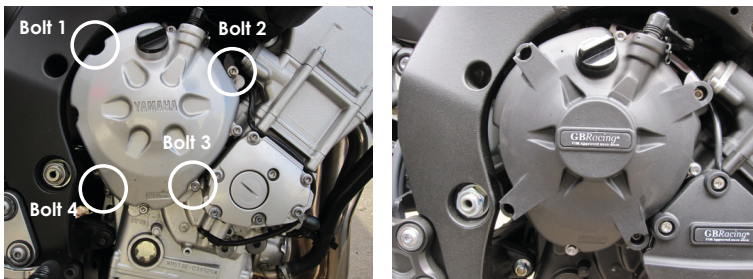

SECONDARY PULSE COVER
PART NO. EC-FZ8-2010-3-GBR

- 1 Remove 3 off existing bolts on the stock aluminium pulse cover, corresponding to the Secondary Pulse Cover. Shown as bolt positions 1, 2, & 3.
- 2 Place the Secondary Engine Pulse Cover over the stock aluminium pulse cover. Loosely screw down bolts 1, 2, & 3 using the supplied M6x25mm bolts.
- 3 Tighten bolts to a Torque of 10Nm as per manufacturers recommendations.
DO NOT OVERTIGHTEN.

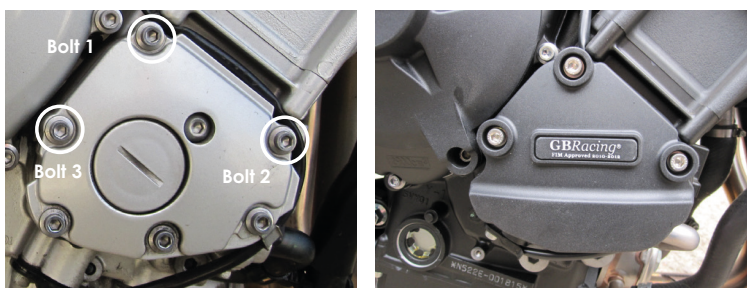

SECONDARY CRANK COVER
PART NO. EC-FZ8-2010-4-GBR

- 1 Remove 2 existing bolts from the stock crank cover, shown as position Bolt 1 & 2.
- 2 Place the Secondary Pulse Cover over the stock cover.
- 3 Assemble 2 replacement bolts loosely in the correct position as shown.
- 4 Tighten bolts to a Torque of 10Nm as per manufacturers recommendations.
DO NOT OVERTIGHTEN.

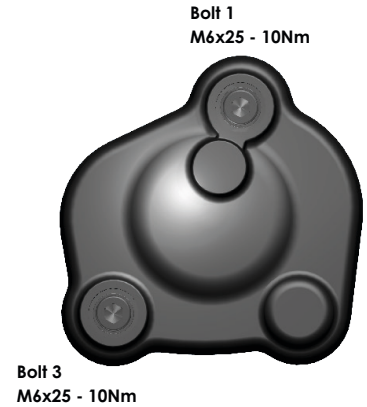
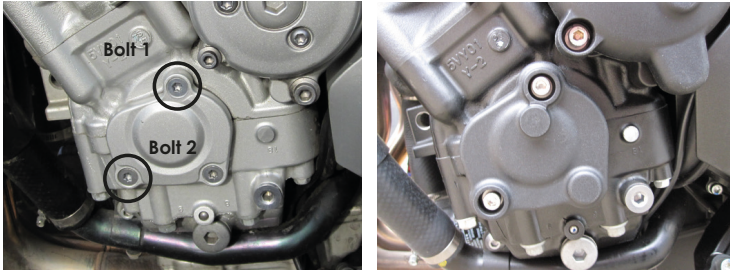

PADDOCK STAND / BOBBIN SET - PART NO. BA12-6-GBR-SET

- 1 Assemble M6 x 40mm Bolt & M6 Washer fthrough the moulded bobbin.
- 2 Tighten bolts to swing arm boss, 8 Nm.
DO NOT OVERTIGHTEN



LOWER CHAIN GUARD – PART NO. CGA10-GBR

- 1 Assemble 2 bolts and washers through the lower chain guard into the Black Anodised aluminium mounting block CGA10-2.
- 2 Position the assembly underneath the swing arm, closing the gap to the rear sprocket.
Note : There should be a 5mm minimum gap from the bike chain to the lower chain guard.
- 3 Mark off the chosen hole positions.
- 4 Drill & Tap the marked holes , M6 - (Drill 5mm Dia. for tapping)
- 5 Disassemble the Black Anodised block from the assembly, and mount the block to the underside of the swing arm using the remaining 2 bolts and washers.
- 6 Re-assemble the lower chain guard to the fixed bracket.



www.GBRacing.eu

Protection Bundle: CP-FZ8-2010-CS-GBR

EC-R1-2007-1-GBR, EC-FZ8-2010-2-GBR, EC-FZ8-2010-3-GBR, EC-FZ8-2010-4-GBR, CGA10-GBR, BA12-6-GBR-SET

Engine Cover Set: EC-FZ8-2010-SET-GBR

EC-R1-2007-1-GBR, EC-FZ8-2010-2-GBR, EC-FZ8-2010-3-GBR, EC-FZ8-2010-4-GBR