



S1000RR 2017 &  
S1000XR 2015

# FITTING INSTRUCTIONS

TO BE FITTED BY A QUALIFIED TECHNICIAN



THIS SHEET INCLUDES FITTING INSTRUCTIONS FOR THE FOLLOWING PARTS:

Secondary Alternator Cover Part No. EC-S1000RR-2009-1-GBR / Secondary Clutch Cover Part No. EC-S1000XR-2015-2-GBR /  
Secondary Pulse Cover Part No. EC-S1000RR-2009-3-GBR

Bullet Frame Race Slider Set - STREET - Part No. FS-S1000RR-2009-S / Bullet Frame Race Slider Set - RACE - Part No. FS-S1000RR-2009-R  
Bobbins Set Part No. BA12-8-GBR-SET / Lower Chain Guard Part No. CGA11-GBR



## SECONDARY ALTERNATOR COVER PART NO. EC-S1000RR-2009-1-GBR

- 1 Remove 4 existing stretch bolts from the stock Alternator cover, shown as position Bolt 1, 2, 3 & 4.
- 2 Place the Secondary Alternator Cover over the stock cover.
- 3 Assemble 4 replacement stainless steel M6x40 TORX bolts loosely in the correct position as shown.
- 4 Tighten bolts to a Torque of 10Nm. DO NOT OVERTIGHTEN.

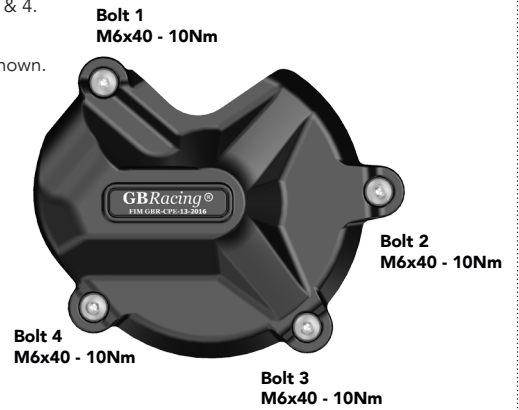
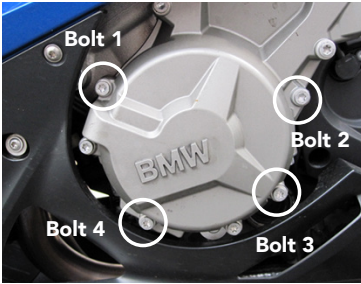

## SECONDARY CLUTCH COVER PART NO. EC-S1000XR-2015-2-GBR

- 1 Remove Upper fairing.
- 2 Remove 3 existing bolts from the stock clutch cover, shown as position Bolt 1, 2 & 3.
- 3 Place the Secondary Clutch Cover over the stock cover.
- 4 Assemble 3 replacement M6x40 TORX bolts, loosely in the correct position as shown.
- 5 Tighten bolts to a Torque of 10Nm. DO NOT OVERTIGHTEN.
- 6 Re-Fit Upper Fairing.

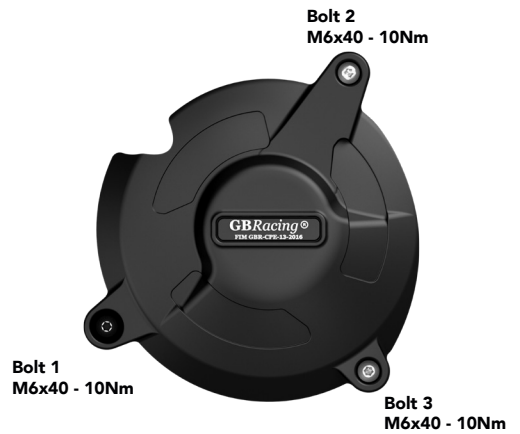
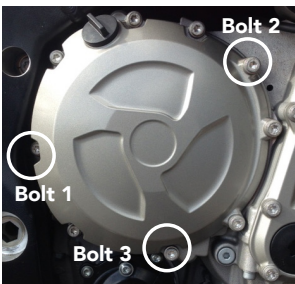

## SECONDARY PULSE COVER PART NO. EC-S1000RR-2009-3-GBR

- 1 Remove 4 existing bolts from the stock pulse cover, shown as position Bolts 1, 2, 3 & 4.
- 2 Place the Secondary Pulse Cover over the stock cover.
- 3 Assemble 4 replacement M6x30 TORX bolts, loosely in the correct position as shown.
- 4 Tighten bolts to a Torque of 10Nm. DO NOT OVERTIGHTEN.

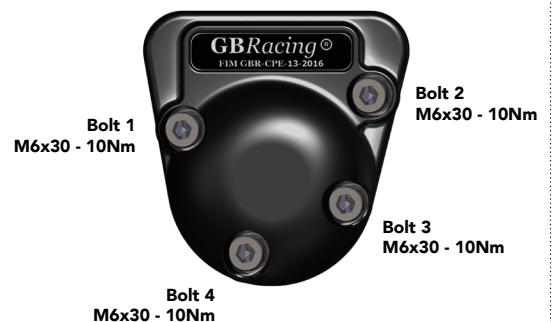
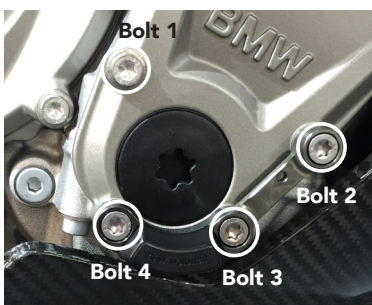



S1000RR 2017 &  
S1000XR 2015

# FITTING INSTRUCTIONS

TO BE FITTED BY A QUALIFIED TECHNICIAN



## BULLET FRAME SLIDER - LEFT HAND SIDE - STREET

**PART NO. FS-S1000RR-2009-LHS-S**

- 1 Remove upper engine mounting bolt, located through the fairing opening.
- 2 Assemble bolt through the aluminium bush into correct position.
- 3 Tighten to 40NM torque.
- 4 Slide bullet moulding onto aluminium bush.
- 5 Screw M6 bolt into front of bullet moulding hand tight.



## BULLET FRAME SLIDER - RIGHT HAND SIDE - STREET

**PART NO. FS-S1000RR-2009-RHS-S**

- 1 Remove upper engine mounting bolt, located through the fairing opening.
- 2 Assemble bolt through the aluminium bush into correct position.
- 3 Tighten to 40NM torque.
- 4 Slide bullet moulding onto aluminium bush.
- 5 Screw M6 bolt into front of bullet moulding hand tight.



## BULLET FRAME SLIDER - LEFT HAND SIDE - RACE

**PART NO. FS-S1000RR-2009-LHS-R**

- 1 Remove upper engine mounting bolt, located through the fairing opening.
- 2 Assemble bolt through the aluminium bush into correct position.
- 3 Tighten to 40NM torque.
- 4 Slide bullet moulding onto aluminium bush.
- 5 Screw M6 bolt into front of bullet moulding hand tight.



## BULLET FRAME SLIDER - RIGHT HAND SIDE - RACE

**PART NO. FS-S1000RR-2009-RHS-R**

- 1 Remove upper engine mounting bolt, located through the fairing opening.
- 2 Assemble bolt through the aluminium bush into correct position.
- 3 Tighten to 40NM torque.
- 4 Slide bullet moulding onto aluminium bush.
- 5 Screw M6 bolt into front of bullet moulding hand tight.



## PADDOCK STAND / BOBBIN SET

**PART NO. BA12-8-GBR-SET**

- 1 Assemble M8 x 40mm Bolt through the moulded bobbin.
  - 2 Tighten bolts to swing arm boss, 8 Nm.
- DO NOT OVERTIGHTEN

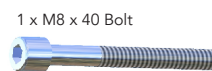

1 x Moulded Paddock Stand / Bobbin

## LOWER CHAIN GUARD

**PART NO. CGA11-GBR**

- 1 Assemble 2 bolts and washers through the lower chain guard into the Black Anodised aluminium mounting block CGA11-B.
- 2 Position the assembly underneath the swing arm, closing the gap to the rear sprocket.  
Note : There should be a 5mm minimum gap from the bike chain to the lower chain guard.
- 3 Mark off the chosen hole positions.
- 4 Drill & Tap the marked holes , M6 - (Drill 5mm Dia. for tapping)
- 5 Disassemble the Black Anodised block from the assembly, and mount the block to the underside of the swing arm using the remaining 2 bolts and washers.
- 6 Re-assemble the lower chain guard to the fixed bracket.



Engine Cover Set: **EC-S1000RR-2017-SET-GBR:** EC-S1000RR-2009-1-GBR, EC-S1000XR-2015-2-GBR, EC-S1000RR-2009-3-GBR