

THIS SHEET INCLUDES FITTING INSTRUCTIONS FOR THE FOLLOWING PARTS:

Secondary Alternator Cover Part No. EC-K890-GP-2022-1-GBR / Secondary Clutch Cover Part No. EC-K890-GP-2022-2-GBR /
Secondary Water Pump Cover Part No. EC-790-2018-5-GBR



SECONDARY ALTERNATOR COVER PART NO. EC-K890-GP-2022-1-GBR

- 1 Remove 3 existing bolts from the stock Alternator cover, shown as position Bolt 1, 2 & 3.
- 2 Place the Secondary Alternator Cover over the stock cover.
- 3 Assemble 3 replacement bolts loosely in the correct position as shown.
- 4 Tighten bolts to a Torque of 10Nm as per Manufacturer's recommendations.
DO NOT OVERTIGHTEN.

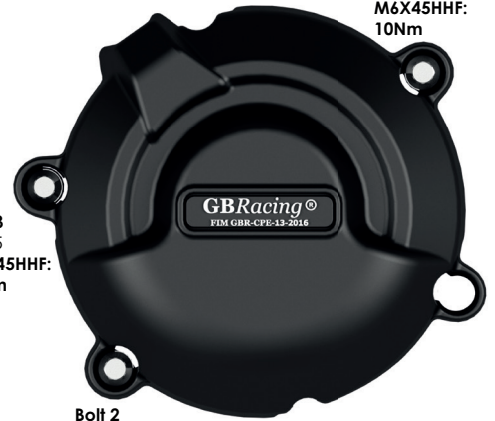
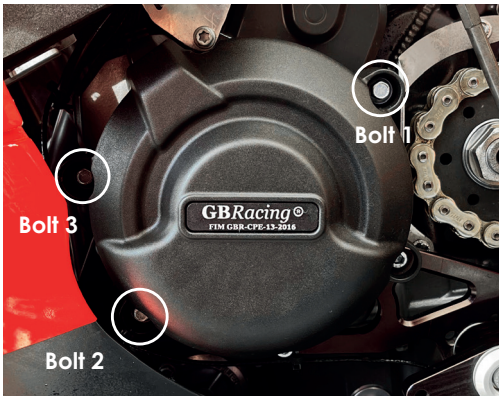

Bolt 3
SPB-5
M6X45HHF:
10Nm

Bolt 1
SPB-5
M6X45HHF:
10Nm

Bolt 2
SPB-5
M6X40HHF:
10Nm

SECONDARY CLUTCH COVER PART NO. EC-K890-GP-2022-2-GBR

- 1 Remove 3 existing bolts from the stock Clutch cover, shown as position Bolt 1, 2 & 3
- 2 Place the Secondary Clutch Cover over the stock cover.
- 3 Assemble 3 replacement bolts loosely in the correct position as shown.
- 4 Tighten bolts to a Torque of 10Nm as per Manufacturer's recommendations.
DO NOT OVERTIGHTEN.

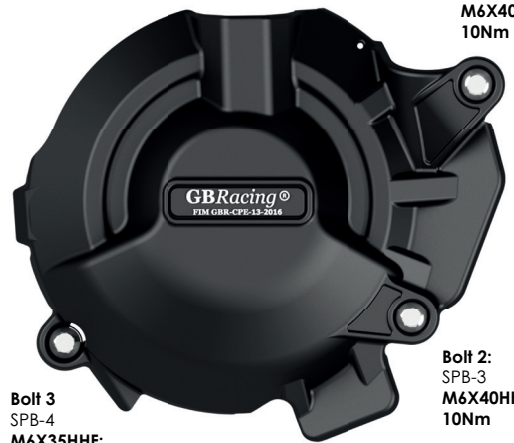
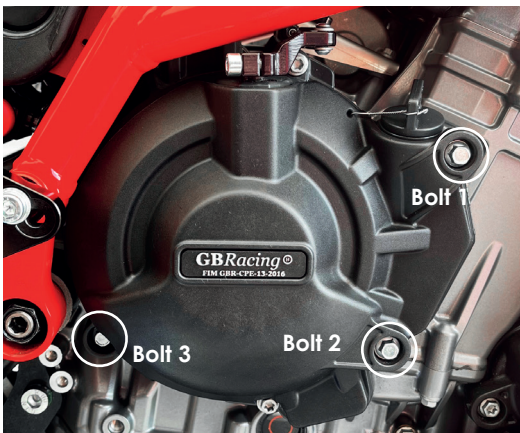

Bolt 3
SPB-4
M6X35HHF:
10Nm

Bolt 1
SPB-3
M6X40HHF:
10Nm

Bolt 2:
SPB-3
M6X40HHF:
10Nm

SECONDARY WATER PUMP COVER PART NO. EC-790-2018-5-GBR

- 1 Fitting requires a COLD engine.
- 2 Decompress the system before loosening existing stock bolts by removing the radiator cap, ONLY WHEN ENGINE IS COLD.
- 3 Have all 3 replacement bolts to hand before removing existing stock bolts.
- 4 Remove 3 existing bolts from the stock water pump cover, shown as position bolts 1, 2 & 3.
Note: When the water pump bolts are removed there will be slight fluid loss.
- 5 Place the secondary water pump over the stock cover.
- 6 Assemble 3 replacement bolts, loosely in the correct position as shown.
- 7 Tighten bolts to a Torque of 10Nm. DO NOT OVERTIGHTEN.
- 8 Check coolant level & top up if necessary before starting engine.

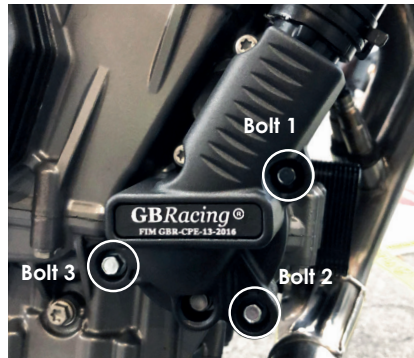
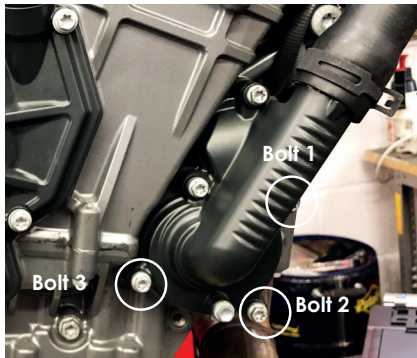
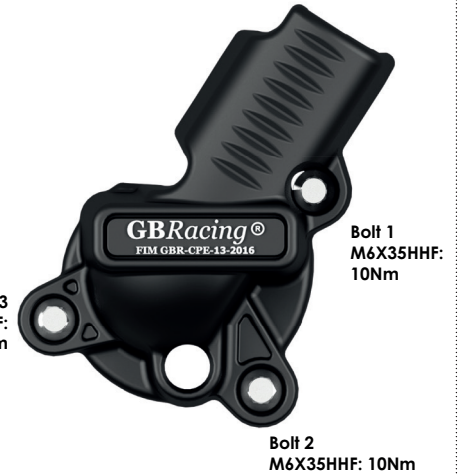

Engine Cover Set: EC-K890-GP-2022-SET-GBR

EC-K890-GP-2022-1-GBR, EC-K890-GP-2022-2-GBR, EC-790-2018-5-GBR

BULLET FRAME SLIDER SET - PART NO. FS-K890-GP-2022-R:

BULLET FRAME SLIDER - LEFT HAND SIDE - RACE PART NO. FS-K890-GP-2022-LHS-R

- 1 Remove Factory Bung
- 2 Drill M8 hole to M10 Thread Pitch 1.5
- 3 Assemble bolt through the aluminium bush into correct position.
- 4 Tighten to 40Nm torque.
- 5 Slide bullet moulding onto aluminium bush.
- 6 Screw M6 bolt into front of bullet moulding hand tight.



BULLET FRAME SLIDER - RIGHT HAND SIDE - RACE PART NO. FS-K890-GP-2022-RHS-R

- 1 Remove Factory Bung
- 2 Drill M8 hole to M10 Thread Pitch 1.5
- 3 Assemble bolt through the aluminium bush into correct position.
- 4 Tighten to 40Nm torque.
- 5 Slide bullet moulding onto aluminium bush.
- 6 Screw M6 bolt into front of bullet moulding hand tight.

