

THIS SHEET INCLUDES FITTING INSTRUCTIONS FOR THE FOLLOWING PARTS:

Secondary Alternator Cover Part No. EC-ZXR400-2018-1-GBR / Secondary Clutch Cover Part No. EC-ZXR400-2018-2-GBR /

Secondary Water Pump Cover Part No. EC-ZXR400-2018-5-GBR /

Frame Sliders RACE Part No. FS-ZXR400-2018-LHS-R & FS-ZXR400-2018-RHS-R

Paddock Stand Bobbin Set Part No. BA12-8-GBR-SET / Lower Chain Guard Assembly Part No. CGA18-GBR-SET



SECONDARY ALTERNATOR COVER
PART NO. EC-ZXR400-2018-1-GBR

1. Remove nearside lower belly panel. The lower part of the main fairing panel will need to be loosened to allow for access to Bolt 4 in terms of its removal and replacement.
2. Remove 4 existing bolts from the stock Alternator cover, shown as position Bolt 1, 2, 3 & 4.
3. Place the Secondary Alternator Cover over the stock cover.
4. Assemble 4 replacement bolts loosely in the correct positions as shown: 3 x M6X40HHF & 1 x M6X45HHF.
5. Tighten bolts to a Torque of 11Nm as per manufacturer's recommendations. DO NOT OVERTIGHTEN.
6. Re-fit lower belly panel.

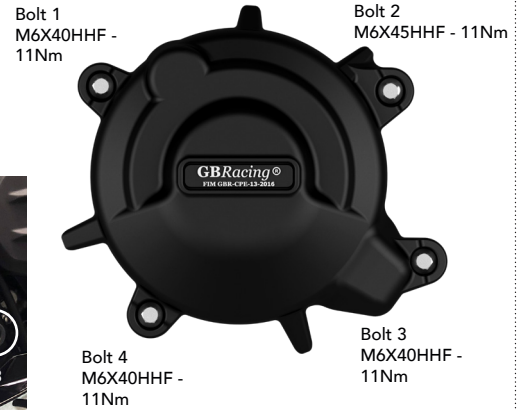
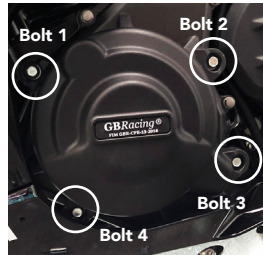

SECONDARY CLUTCH COVER
PART NO. EC-ZXR400-2018-2-GBR

1. Remove Lower Fairing panel.
2. Remove 4 existing bolts from the Clutch cover, shown as position Bolt 1, 2, 3 & 4.
3. Place the Secondary Clutch Cover over the stock cover.
4. Assemble 4 replacement bolts M6X30HHF loosely in the correct position as shown.
5. Tighten bolts to a Torque of 11Nm as per manufacturer's recommendations. DO NOT OVERTIGHTEN.
6. Re-fit Lower Fairing panel.

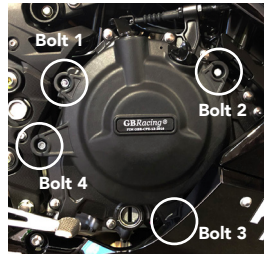

SECONDARY WATER PUMP COVER
PART NO. EC-ZXR400-2018-5-GBR

1. Remove Lower Fairing panel.
2. Remove 3 existing bolts from the water pump cover, shown as position Bolt 1, 2, & 3.
3. Place the Secondary water pump cover the stock cover.
4. Assemble 3 replacement bolts M6X55HHF loosely in the correct position as shown.
5. Tighten bolts to a Torque of 11Nm as per manufacturer's recommendations. DO NOT OVERTIGHTEN.
6. Re-fit Lower Fairing panel.

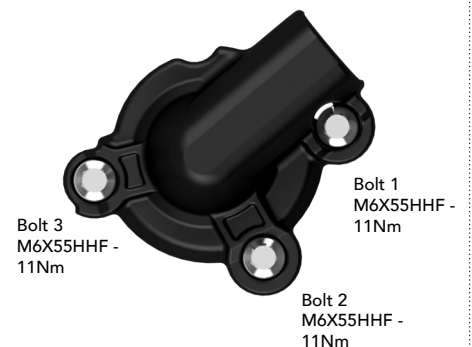
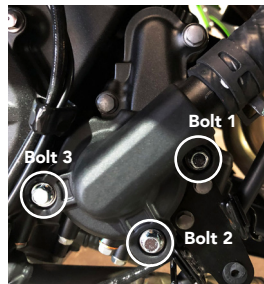

Engine Cover Set: EC-ZXR400-2018-SET-GBR

EC-ZXR400-2018-1-GBR, EC-ZXR400-2018-2-GBR, EC-ZXR400-2018-5-GBR

www.GBRacing.eu

RACE Bullet Frame Slider SET Part No: FS-ZXR400-2018-R:

BULLET FRAME SLIDER - LEFT HAND SIDE - RACE
PART NO. FS-ZXR400-2018-LHS-R

- 1 Remove fairing.
- 2 Remove upper engine mounting bolt, located through the fairing opening.
- 3 Assemble bolt through the aluminium bush and extension bush into correct position.
- 4 Drill fairing.
- 5 Tighten to 44Nm torque.
- 6 Replace fairing.
- 7 Slide bullet moulding onto aluminium bush.
- 8 Screw M6 bolt into front of bullet moulding hand tight.

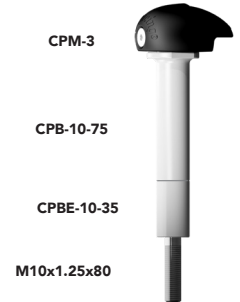

BULLET FRAME SLIDER - RIGHT HAND SIDE - RACE
PART NO. FS-ZXR400-2018-RHS-R

- 1 Remove fairing.
- 2 Remove upper engine mounting bolt, located through the fairing opening.
- 3 Assemble bolt through the aluminium bush and extension bush into correct position.
- 4 Drill fairing.
- 5 Tighten to 44Nm torque.
- 6 Replace fairing.
- 7 Slide bullet moulding onto aluminium bush.
- 8 Screw M6 bolt into front of bullet moulding hand tight.



PADDOCK STAND / BOBBIN SET PART NO. BA12-8-GBR-SET

- 1 Assemble M8 x 40mm Bolt through the moulded bobbin.
- 2 Tighten bolts to swing arm boss, 8 Nm.
DO NOT OVERTIGHTEN

1 x M8 x 40 Bolt



1 x Moulded Paddock Stand / Bobbin

LOWER CHAIN GUARD ASSEMBLY
PART NO. CGA18-GBR-SET

- 1 Assemble one M8 x 40mm bolt through one of the moulded bobbins and place on the chain guard as per **Fig 1**.
- 2 Bolt on to left hand side of the swing arm.
- 3 Assemble the remaining M8 x 40mm bolt through the mould and place the black aluminium washer on the back as per **Fig 2**.
- 4 Position the assembly on the paddock stand bobbin mount on the right side of the swing arm.
- 5 Tighten bolts on both sides of swing arm to 8 Nm.

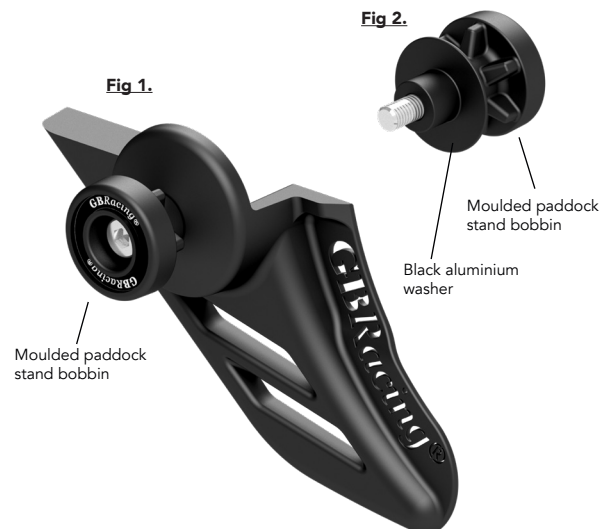

Parts included:

- 1 x CG18-GBR Chain Guard
- 2 x M8 x 40 Bolt
- 1 x BA12-8-GBR
- 1 x BA12A-GBR moulded paddock stand bobbins