

**THIS SHEET INCLUDES FITTING INSTRUCTIONS FOR THE FOLLOWING PARTS:**

Secondary Alternator Cover Part No. EC-MT09-2014-1-GBR / Secondary Clutch Cover Part No. EC-MT09-2014-2-GBR /  
Secondary Pulse Cover Part No. EC-R1-MT09-2014-GBR / Secondary Water Pump Cover Part No. EC-MT09-2014-5-GBR  
Paddock Stand / Bobbin Kit Part No. BA12-6-GBR-SET / Bullet Frame Sliders Part No. FS-XSR900-2015-S



**SECONDARY ALTERNATOR COVER PART NO. EC-MT09-2014-1-GBR**

- 1 Prepare the alternator cover ready for installation with Bolt 3 inserted into the cover.
- 2 Place a container that can catch any lubricants underneath the area of the alternator.
- 3 Remove the 4 standard bolts. Remove Bolt 3 last as when it is removed, oil will leak from the thread until a bolt is placed back inside the thread. If on a paddock stand, this will aid the process immensely.
- 4 Place the secondary alternator cover against the standard alternator and thread Bolt 3 but do not tighten at this stage, this will stop the oil leaking. Insert the remaining 3 bolts and tighten all 4 bolts to 10Nm as per Manufacturer's recommendations. **DO NOT OVERTIGHTEN.**
- 5 Check the oil level.

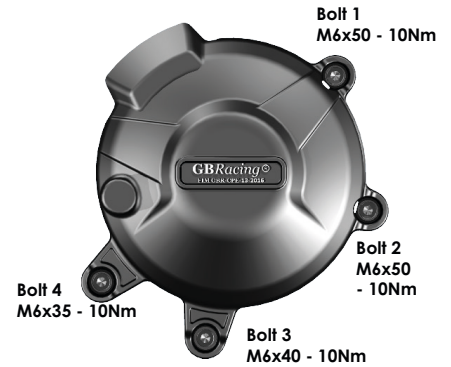

**SECONDARY CLUTCH COVER PART NO. EC-MT09-2014-2-GBR**

- 1 Remove Bolts 1 and 2 and then remove the plastic heat shield from the clutch cover as shown in Fig 1. Replace Bolts 1 & 2 and tighten to 10Nm.
- 2 Remove bolts 3,4,5 & 6 as shown in Fig 2 .
- 3 Place the secondary clutch cover against the standard cover using the supplied bolts. Take care when placing the cover at Bolt position 5 so as not to snag the electrical cable.
- 4 Tighten all 4 bolts as shown in Fig 3 to 10Nm as per Manufacturer's recommendations. **DO NOT OVERTIGHTEN.**

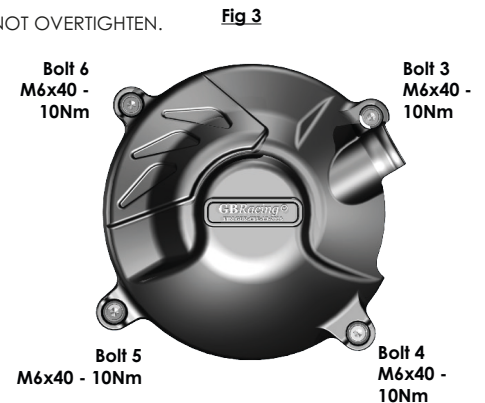
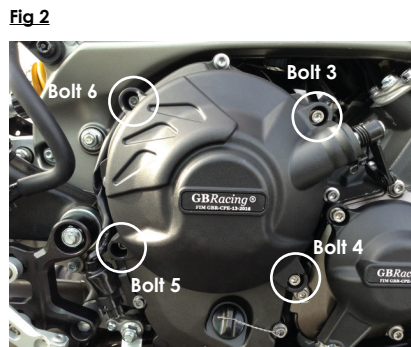
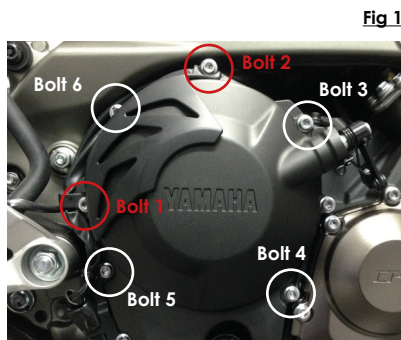

**SECONDARY PULSE COVER PART NO. EC-MT09-2014-3-GBR**

- 1 Remove the 4 standard bolts
- 2 Place the secondary pulse cover against the standard cover using the supplied bolts.
- 3 Tighten all 4 bolts to 10nm as per manufacturer's recommendations **DO NOT OVERTIGHTEN**

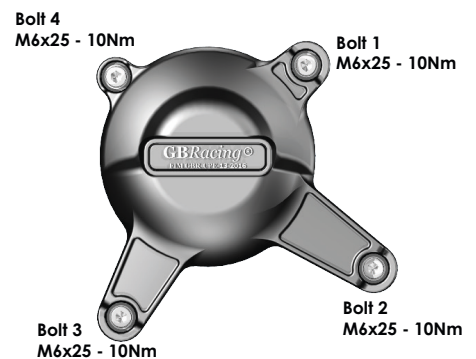
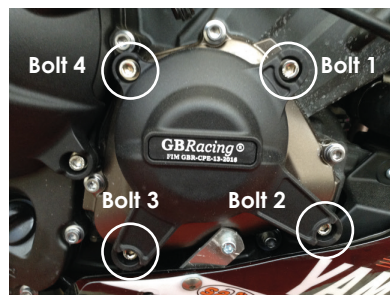



**SECONDARY WATER PUMP COVER PART NO. EC-MT09-2014-5-GBR**

- 1 Prepare the water pump secondary cover ready for installation. Place the copper washer onto the supplied bolt at bolt position 2 as per Fig.1 and insert the bolt into the correct position on the secondary cover.
- 2 Undo the existing jubilee clip and remove from the hose. Turn 180 degrees and reinstall the clip so that the clamp is at the top of the hose but do not tighten at this stage to allow movement as shown in Fig.2.
- 3 Place a container that can catch any lubricants underneath the area of the water pump.
- 4 Remove the 4 standard bolts as shown in Fig.1. Note: remove Bolt 2 last as when it is removed, a small amount of water will leak from the thread until a bolt is placed back inside the thread. If on a paddock stand, this will aid the process immensely.
- 5 Place the copper washer from the original Bolt 2 onto the the thread of the new supplied Bolt 2 (M6x25) as per Fig. 4. and insert bolt into cover. Put the bolt in to the cover and then put the new supplied copper washer on to the thread of the bolt so that it is in the correct order as per Fig. 4. Then place the secondary water pump cover against the standard cover and thread Bolt 2 until finger tight but do not tighten at this stage, this will stop the water leaking.
- 6 Insert the remaining 3 bolts and tighten all 4 bolts to 10Nm as per manufacturer's recommendations. DO NOT OVERTIGHTEN
- 7 Tighten the jubilee clamp but do not overtighten.

Fig. 1

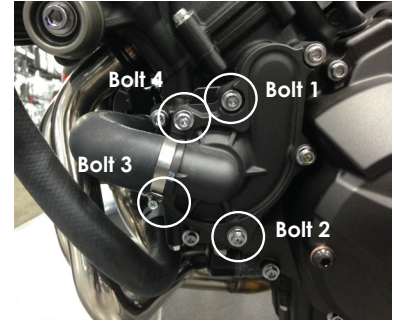

Fig. 2

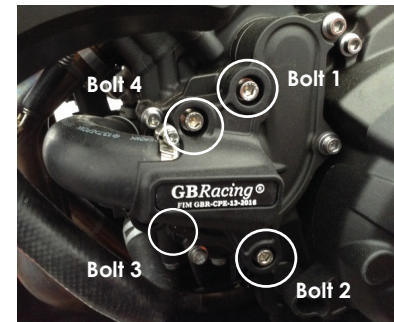

Fig. 3

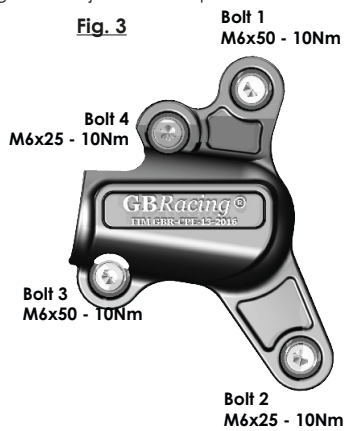
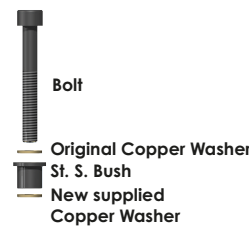

Fig. 4



SET:

**Engine Cover Set: EC-MT09-2014-SET-GBR**

Secondary Alternator Cover Part No. EC-MT09-2014-1-GBR / Secondary Clutch Cover Part No. EC-MT09-2014-2-GBR /  
Secondary Pulse Cover Part No. EC-R1-MT09-2014-GBR / Secondary Water Pump Cover Part No. EC-MT09-2014-5-GBR

**PADDOCK STAND / BOBBIN SET - PART NO. BA12-6-GBR-SET**

- 1 Assemble M6 x 40mm Bolt & M6 Washer fthrough the moulded bobbin.
- 2 Tighten bolts to swing arm boss, 8 Nm.  
DO NOT OVERTIGHTEN



**RACE** Bullet Frame Slider SET Part No: **FS-XSR900-2015-S:**

**BULLET FRAME SLIDER - LEFT HAND SIDE - STREET**  
**FS-XSR900-2015-LHS-S**

- 1 Remove front engine mounting bolt.
- 2 Assemble bolt through the aluminium bush into correct position.
- 3 Tighten to 40Nm torque.
- 4 Slide bullet moulding onto aluminium bush.
- 5 Screw M6 bolt into front of bullet moulding hand tight.



**BULLET FRAME SLIDER - RIGHT HAND SIDE - STREET**  
**FS-XSR900-2015-RHS-S**

- 1 Remove front engine mounting bolt.
- 2 Assemble bolt through the aluminium bush into correct position.
- 3 Tighten to 40Nm torque.
- 4 Slide bullet moulding onto aluminium bush.
- 5 Screw M6 bolt into front of bullet moulding hand tight.

