

THIS SHEET INCLUDES FITTING INSTRUCTIONS FOR THE FOLLOWING PARTS:

Secondary Alternator Cover Part No. EC-R6-2008-1-GBR / Secondary Clutch Cover Part No. EC-R6-2008-2-GBR / Secondary Pulse Cover Part No. EC-R6-2008-3-GBR / Secondary Alternator Cover KIT Part No. EC-R6-2008-1-K-GBR / Bullet Frame Race Slider Set Part No. FS-R6-2006-R / Bullet Frame Race Slider Set Part No. FS-R6-2006-S / Paddock Stand / Bobbin Set Part No. BA12-6-GBR-SET / Lower Chain Guard Part No. CGA10-GBR / Brake Lever Guard Part No. BLG-R1-2006-GBR



SECONDARY ALTERNATOR COVER – PART NO. EC-R6-2008-1-GBR

Please note: 2017-2020 models: the small metal cover at the bottom of the alternator will need to be removed and a replacement bolt M6X25A2 will need to be added in the location between bolt position 2 & 3. Please add this bolt to your order separately as this will not be included when ordering this part.

- 1 Remove the Fairing.
- 2 Remove 4 off existing bolts on the stock aluminium Alternator cover, corresponding to the STOCK Secondary Engine Alternator Cover. Shown as bolt positions 1,2, 3 & 4.
- 3 Place the STOCK Secondary Engine Alternator cover over the stock aluminium alternator cover. Loosely screw down all Bolt using the supplied M6 x 30mm replacement bolts.
- 4 Tighten all 4 bolts to a torque of 10 N/m as per manufacturer's recommendations. **DO NOT OVERTIGHTEN**
- 5 Refit the fairing.



SECONDARY CLUTCH COVER – PART NO. EC-R6-2008-2-GBR

- 1 Remove the Fairing.
- 2 Remove 3 off existing bolts on the aluminium Clutch cover, corresponding to the Secondary Engine Clutch Cover. Shown as bolt positions 1,2 & 3.
- 3 Place the Secondary Engine Clutch Cover over the stock aluminium clutch cover. Loosely screw down Bolt position 1 FIRST (Note: the moulded cover may need to be pushed to aid alignment), then bolts 2 & 3 using the supplied M6X50A2 & M6X35A2mm replacement bolts.
- 4 Tighten all 3 bolts to a torque of 10 N/m as per manufacturer's recommendations. **DO NOT OVERTIGHTEN**
- 5 Refit the fairing.

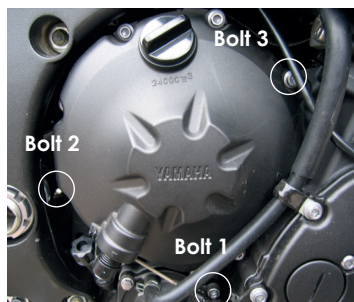

SECONDARY PULSE COVER – PART NO. EC-R6-2008-3-GBR

- 1 Remove the Lower Fairing.
- 2 Remove 3 off existing bolts on the aluminium Pulse cover, corresponding to the Secondary Engine Pulse Cover. Shown as bolt positions 1,2 & 3.
- 3 Place the Secondary Engine Pulse Cover over the stock aluminium pulse cover, holding the clutch cable steel bracket in place. Loosely screw down Bolts 2 & 3 with the supplied replacement M6X30A2 Bolts, lining up the steel bracket. Then the remaining supplied replacement M6X25A2mm Bolt.
- 4 Tighten all 3 bolts to a torque of 10 N/m as per manufacturer's recommendations. **DO NOT OVERTIGHTEN**

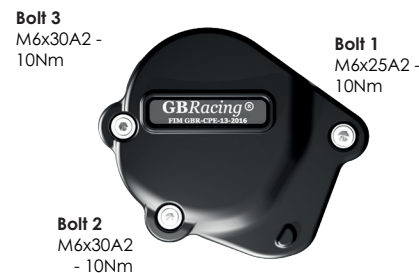
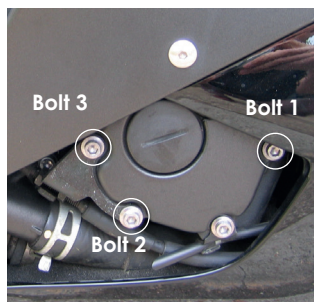

SECONDARY ALTERNATOR COVER – KIT – PART NO. EC-R6-2008-1-K-GBR

- 1 Remove the Fairing.
- 2 Remove 4 off existing bolts on the aluminium KIT Alternator cover, corresponding to the Secondary Engine KIT Alternator Cover. Shown as bolt positions 1,2,3 & 4.
- 3 Place the Secondary Engine KIT Alternator cover over the KIT aluminium KIT alternator cover. Loosely screw down Bolt position 1 (Note: the moulded cover may need to be pushed to aid alignment), then bolts 2, 3 & 4 using the supplied M6X35A2mm replacement bolts.
- 4 Tighten all 4 bolts to a torque of 10 N/m as per manufacturer's recommendations. **DO NOT OVERTIGHTEN**
- 5 Refit the fairing.

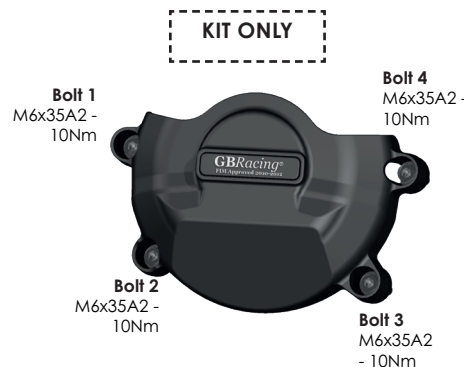
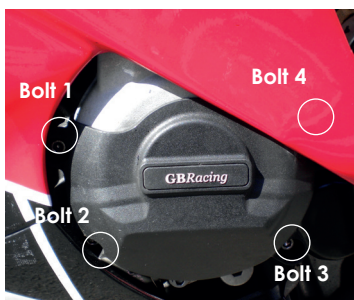

Please note: BULLET FRAME SLIDERS:

Nearside/offside fairing may require drilling dependent the manufacture year of bike. If you cannot see your forward engine mount, drilling may be required.

**BULLET FRAME SLIDER - RIGHT HAND SIDE - RACE -
PART NO. FS-R6-2006-RHS-R**



INSTRUCTIONS FOR THESE PARTS:

1. Remove front engine mounting bolt, located through the fairing opening.
2. Assemble bolt through the aluminium bush into correct position.

**BULLET FRAME SLIDER - LEFT HAND SIDE - RACE -
PART NO. FS-R6-2006-LHS-R**



3. Tighten to 25NM torque.
4. Slide bullet moulding onto aluminium bush.
5. Screw M6 bolt into front of bullet moulding hand tight.

**BULLET FRAME SLIDER - RIGHT HAND SIDE - STREET
- PART NO. FS-R6-2006-RHS-S**



INSTRUCTIONS FOR THESE PARTS:

1. Remove front engine mounting bolt, located through the fairing opening.
2. Assemble bolt through the aluminium bush into correct position.

**BULLET FRAME SLIDER - LEFT HAND SIDE - STREET
- PART NO. FS-R6-2006-LHS-S**



3. Tighten to 25NM torque.
4. Slide bullet moulding onto aluminium bush.
5. Screw M6 bolt into front of bullet moulding hand tight.

LOWER CHAIN GUARD - PART NO. CGA10-GBR

1. Assemble 2 bolts and washers through the lower chain guard into the Black Anodised aluminium mounting block CGA10-2.
2. Position the assembly underneath the swing arm, closing the gap to the rear sprocket. Note: There should be a 5mm minimum gap from the bike chain to the lower chain guard.
3. Mark off the chosen hole positions.
4. Drill & Tap the marked holes, M6 - (Drill 5mm Dia. for tapping)
5. Disassemble the Black Anodised block from the assembly, and mount the block to the underside of the swing arm using the remaining 2 bolts and washers.
6. Re-assemble the lower chain guard to the fixed bracket.



PADDOCK STAND / BOBBIN SET - PART NO. BA12-6-GBR-SET

1. Assemble M6 x 40mm Bolt & M6 Washer through the moulded bobbin.
2. Tighten bolts to swing arm boss, 8 Nm.
DO NOT OVERTIGHTEN



BRAKE LEVER GUARD - PART NO. BLG-R1-2006-GBR

FITS STOCK ONLY MODELS YZF-R1 2006-2021 & YZF-R6 2010-2020

1. Remove existing bar end assembly.
2. Assemble bolt through lever guard into spacer (shown in Fig.1) and then insert into handlebar end and tighten M6 Bolt to 15Nm - **DO NOT OVERTIGHTEN.**

Note: Please be aware that there will still be apparent movement in the lever protector due to the fact it is rubber mounted.

Do not ride if you are unsure if it is tight enough and always get a trained technician to confirm.



Fig. 1

