

THIS SHEET INCLUDES FITTING INSTRUCTIONS FOR THE FOLLOWING PARTS:

Secondary Alternator Cover Part No. EC-GSX-8S-M3-1-GBR / Secondary Clutch Cover Part No. EC-GSX-8S-M3-2-GBR /

Secondary Water Pump Cover Part No. EC-GSX-8S-M3-5-GBR /

Bullet Frame Sliders STREET (*Do not fit V-Strom 800DE*) Part Nos. FS-GSX-8S-M3-LHS-S & FS-GSX-8S-M3-RHS-S (*Do not fit V-Strom 800DE*)



SECONDARY ALTERNATOR COVER PART NO. EC-GSX-8S-M3-1-GBR

- 1 Remove 4 existing bolts from the stock alternator cover, shown as position Bolt 1, 2, 3 & 4.
- 2 Place the secondary alternator cover over the stock cover.
- 3 Assemble 4 replacement bolts loosely in the correct position as shown.
- 4 Tighten bolts to a Torque of 11Nm as per Manufacturer's recommendations.
 DO NOT OVERTIGHTEN.

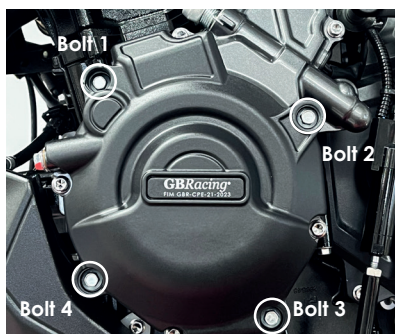
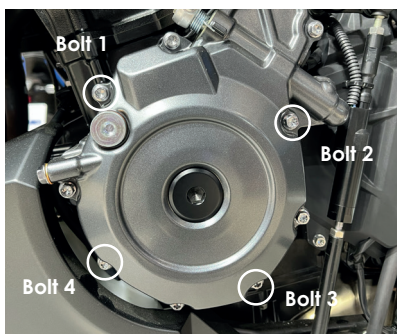

Bolt 1
 SPB-11
 M6X50HHF
 - 11Nm

Bolt 2
 SPB-11
 M6X65HHF
 - 11Nm



Bolt 4
 SPB-11
 M6X50HHF
 - 11Nm

Bolt 3
 SPB-11
 M6X50HHF
 - 11Nm

SECONDARY CLUTCH COVER PART NO. EC-EC-GSX-8S-M3-2-GBR

- 1 Remove 4 existing bolts from the stock clutch cover, shown as position Bolt 1, 2, 3 & 4.
- 2 Place the secondary clutch cover over the stock cover.
- 3 Assemble 4 replacement bolts loosely in the correct position as shown.
- 4 Tighten bolts to a Torque of 11Nm as per Manufacturer's recommendations.
 DO NOT OVERTIGHTEN.

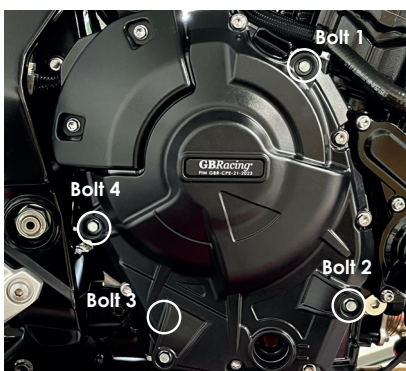
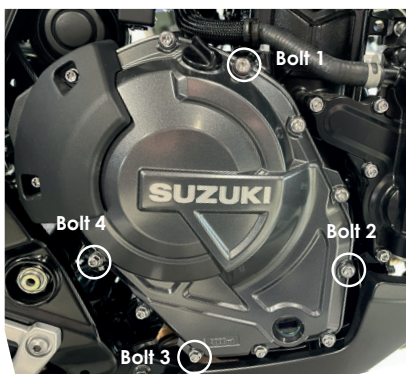

Bolt 1
 SPB-5
 M6X40HHF
 - 11Nm

Bolt 4
 SPB-5
 M6X40HHF
 - 11Nm



Bolt 3
 SPB-5
 M6X40HHF
 - 11Nm

Bolt 2
 SPB-5
 M6X40HHF
 - 11Nm

SECONDARY WATER PUMP COVER PART NO. EC-GSX-8S-M3-5-GBR

- 1 Remove 4 existing bolts from the stock water pump cover, shown as position Bolt 1, 2, 3 & 4.
- 2 Place the secondary water pump cover over the stock cover.
- 3 Assemble 4 replacement bolts loosely in the correct position as shown.
- 4 Tighten bolts to a Torque of 11Nm as per Manufacturer's recommendations.
DO NOT OVERTIGHTEN.

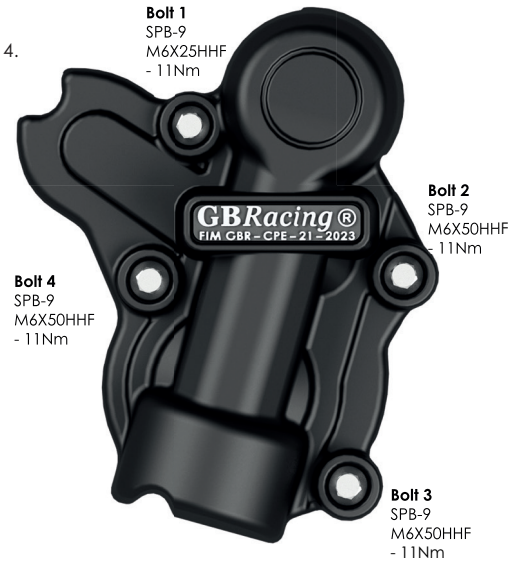
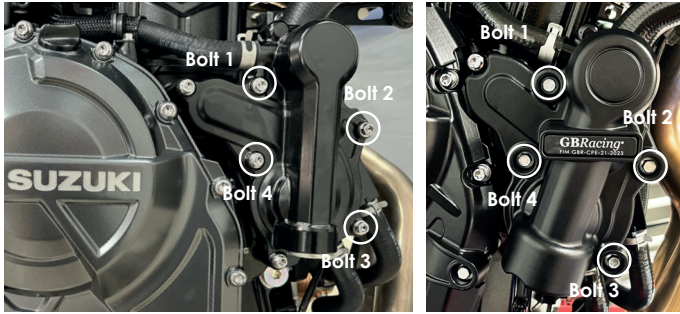

ENGINE COVER SET PART NO. EC-GSX-8S-M3-SET-GBR

BULLET FRAME SLIDER - STREET - SET PART NO. FS-GSX-8S-M3-S:

FIT GSX-8S M3 MODEL ONLY

BULLET FRAME SLIDER - LEFT HAND SIDE - STREET
PART NO. FS-GSX-8S-M3-LHS-S

- 1 Remove upper engine mounting bolt. *NOTE: When removing engine bolt and reinstalling, ensure the washer (see Fig.1) goes back in place between the frame and engine.*
- 2 Assemble bolt through the aluminium bush into correct position.
- 3 Tighten to 50NM torque.
- 4 Slide bullet moulding onto aluminium bush.
- 5 Screw M6 bolt into front of bullet moulding hand tight.

Fig.1

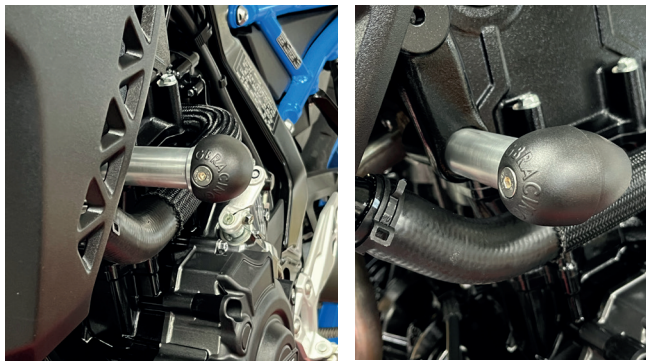
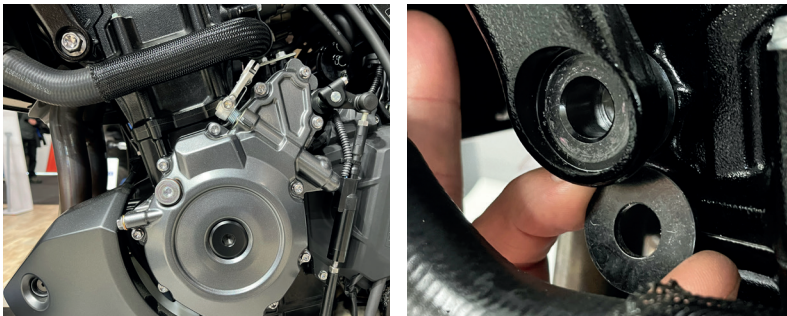

BULLET FRAME SLIDER - RIGHT HAND SIDE - STREET
PART NO. FS-GSX-8S-M3-RHS-S

- 1 Remove upper engine mounting bolt.
- 2 Assemble bolt through the aluminium bush into correct position.
- 3 Tighten to 50NM torque.
- 4 Slide bullet moulding onto aluminium bush.
- 5 Screw M6 bolt into front of bullet moulding hand tight.

