

**THIS SHEET INCLUDES FITTING INSTRUCTIONS FOR THE FOLLOWING PARTS:**

Secondary Alternator Cover Part No. EC-Z900RS-2018-1-GBR / Secondary Clutch Cover Part No. EC-Z900RS-2018-2-GBR /  
Secondary Pulse Cover Part No. EC-Z900RS-2018-3-GBR / Paddock Stand Bobbin Set Part No. BA12-8-GBR-SET /  
Bullet Frame Slider Set STREET Part No. FS-Z900-2017-S



### SECONDARY ALTERNATOR COVER – PART NO. EC-Z900RS-2018-1-GBR

- 1 Remove 4 existing bolts from the stock alternator cover, shown as position Bolt 1, 2, 3 & 4.
- 2 Place the secondary alternator cover over the stock cover.
- 3 Assemble 4 replacement M6X50HHF bolts loosely in the correct position as shown.
- 4 Tighten bolts to a torque of 11Nm as per Manufacturer's recommendations. DO NOT OVERTIGHTEN.

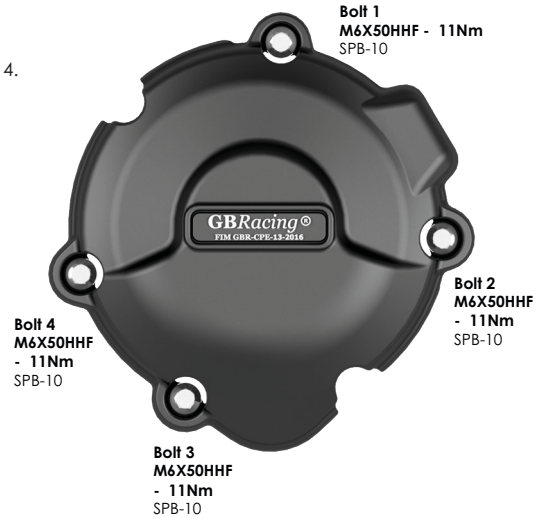
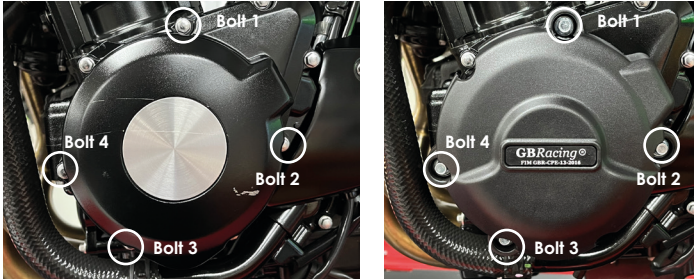

### SECONDARY CLUTCH COVER – PART NO. EC-Z900RS-2018-2-GBR

- 1 Remove 4 existing bolts from the stock clutch cover, shown as position Bolt 1, 2, 3 & 4.
- 2 Place the secondary clutch cover over the stock cover.
- 3 Assemble 4 replacement bolts loosely in the correct position as shown.
- 4 Tighten bolts to a torque of 11Nm as per Manufacturer's recommendations. DO NOT OVERTIGHTEN.

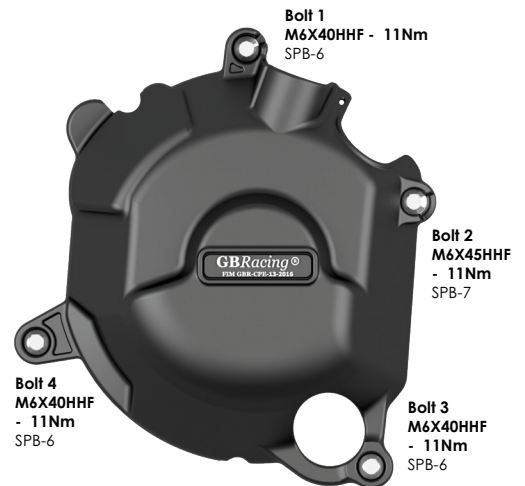
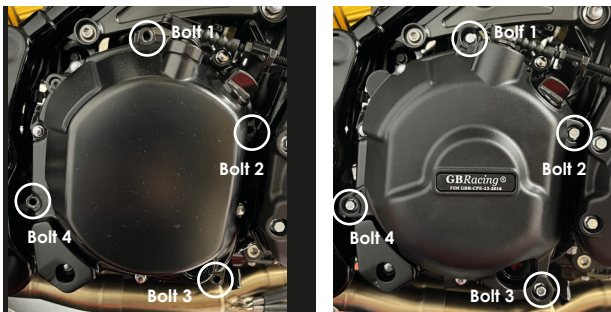

### SECONDARY CLUTCH COVER – PART NO. EC-Z900RS-2018-3-GBR

- 1 Remove 4 existing bolts from the stock pulse cover, shown as position Bolt 1, 2, 3 & 4.
- 2 Place the secondary pulse cover over the stock cover.
- 3 Assemble 4 replacement M6X35HHF bolts loosely in the correct position as shown.
- 4 Tighten bolts to a torque of 11Nm as per Manufacturer's recommendations. DO NOT OVERTIGHTEN.

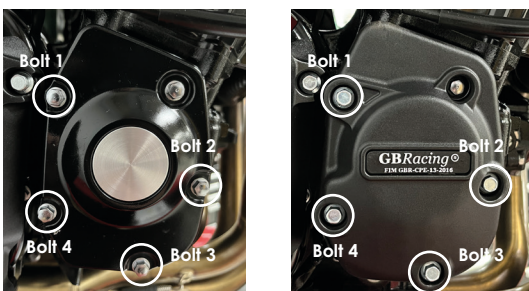

**PADDOCK STAND / BOBBIN SET PART NO. BA12-8-GBR-SET**

- 1 Assemble M8 x 40mm Bolt through the moulded bobbin.
- 2 Tighten bolts to swing arm boss, 8 Nm.  
DO NOT OVERTIGHTEN

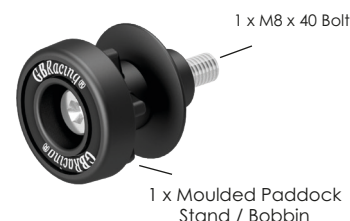

**Bullet Frame Slider SET - STREET - Part No.: FS-Z900-2017-S:**

**BULLET FRAME SLIDER - LEFT HAND SIDE - STREET**  
**PART NO. FS-Z900-2017-LHS-S**

- 1 Remove upper engine mounting bolt - see location at **Fig. 1**
- 2 Assemble bolt through the aluminium bush adding CPBE-10-35 and place into correct position.
- 3 Tighten to 48Nm torque.
- 4 Slide bullet moulding onto aluminium bush.
- 5 Screw M6 bolt into front of bullet moulding hand tight.



**Fig. 1**

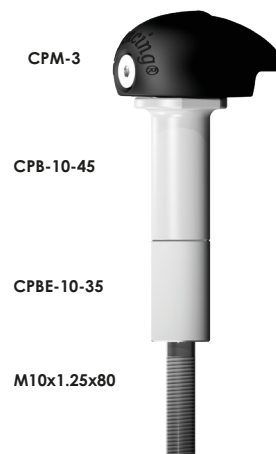
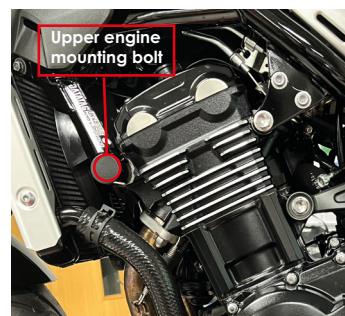

**BULLET FRAME SLIDER - RIGHT HAND SIDE - STREET**  
**PART NO. FS-Z900-2017-RHS-S**

- 1 Remove upper engine mounting bolt - see location at **Fig. 1**
- 2 Assemble bolt through the aluminium bush adding CPBE-10-35 and place into correct position.
- 3 Tighten to 48Nm torque.
- 4 Slide bullet moulding onto aluminium bush.
- 5 Screw M6 bolt into front of bullet moulding hand tight.



**Fig. 1**

